

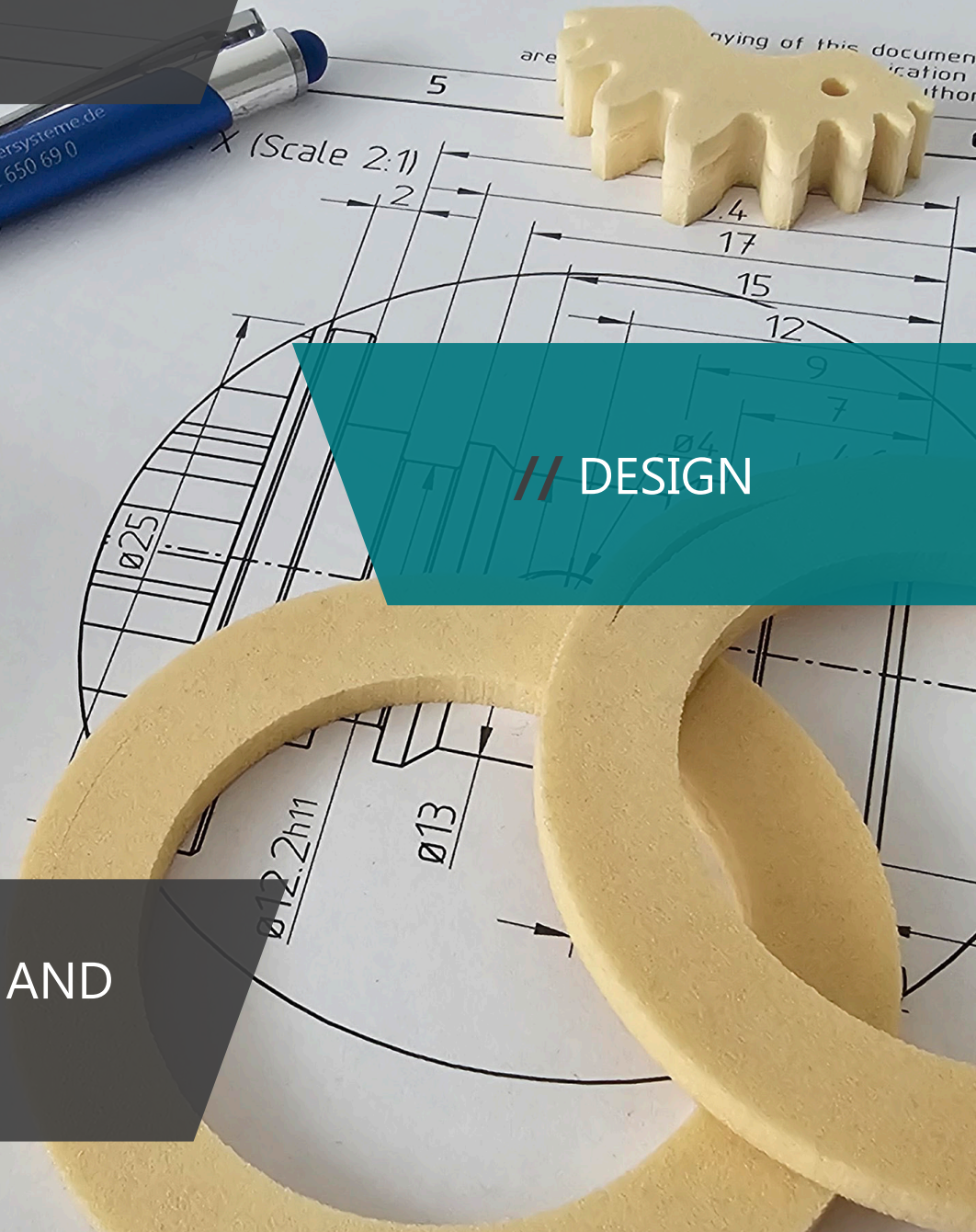

// CONCEPTION



// DESIGN



// INSTALLATION AND ASSEMBLY

# DLS - your safe partner



**Contact:** DLS Schmiersysteme GmbH  
Gewerbering 5  
D- 82140 Olching

**Phone:** +49 8142 650 690  
**E-Mail:** mail@dls-schmiersysteme.de  
**Website:** www.dls-schmiersysteme.de



# Table of contents

## **Grease lubrication**

### **Applicators**

PU-Lubrication-pinion with axis.....	9
PU-Lubrication-pinion with axis, right-angled.....	10
PU-Lubrication-pinion RH with axis, straight.....	11
PU-Lubrication-roller.....	18

## **Oil lubrication**

### **Applicators**

PU-Lubrication-sprocket simplex.....	59
PU-Lubrication-sprocket duplex.....	62
PU-Lubrication-sprocket triplex.....	65
PU-Lubrication-roller for oil.....	69
PU-Lubrication-roller for accumulating conveyor chains.....	73

<b>Accessories.....</b>	<b>92</b>
-------------------------	-----------

<b>Preventive maintenance.....</b>	<b>117</b>
------------------------------------	------------

# Our tribological solution is accurate tailored to your requirements:

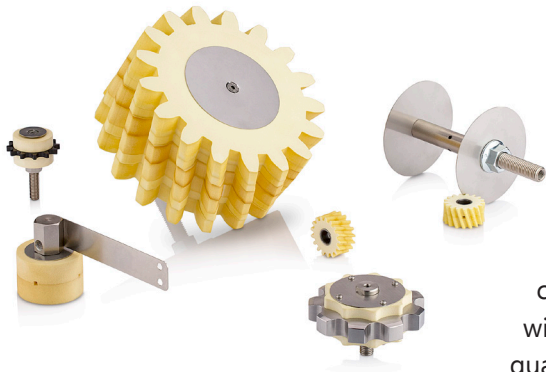

You get lubrication systems for linear guides and ball screws, as well as for open gears and chain drives of all types and sizes.

We advise you personally to work out an optimal solution for your application.

During an on-site visit, we record the general conditions and create a lubrication concept tailored to the respective parameters, without obligation. We also determine the individual lubrication quantity requirements of the individual lubrication points.

We work closely with you to implement the lubrication concept. Subsequent modifications or changes are possible for us at any time!

As a full-range supplier, we provide to you innovative, electronically controlled grease and oil lubricators, as well as lubricating gears, lubrication sprockets and extensive system accessories from stock!

Ideal for original equipment in mechanical engineering as well as for retrofitting existing systems.

**Everything reliable, competent and solid  
from a single source.**



# The PU-Lubrication-pinion

## Lubrication of open gear drives and racks

The teeth of open drives should preferably be relubricated automatically.

- F01 only for open gears and rack and Pinion drives
- F02 for open gears, rack and Pinion drives  
and linear guides in food and Pharmaceutical sector (NSF)
- F03 for open gears, rack and Pinion drives and linear guides

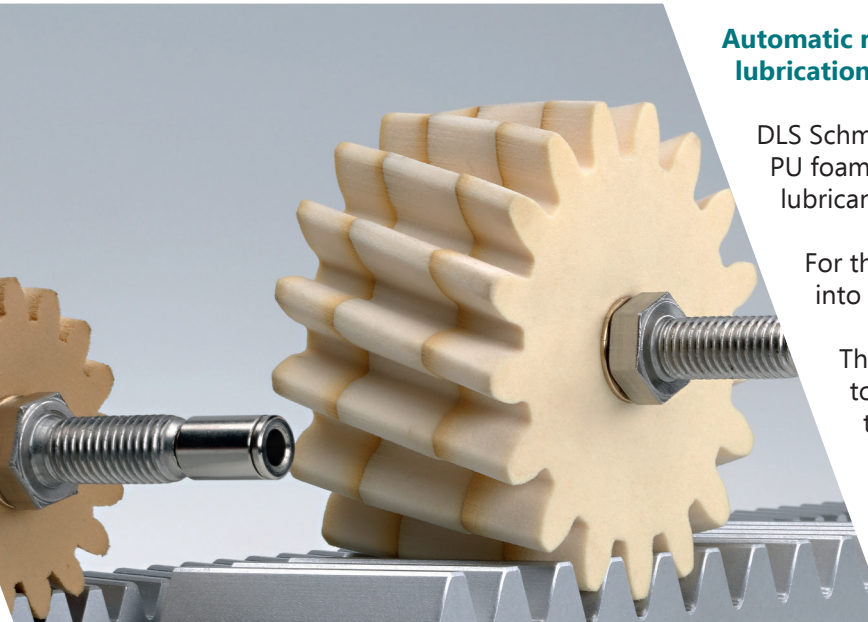

### Automatic relubrication with polyurethane lubrication-pinions

DLS Schmiersysteme supplies lubrication gears made of PU foam for the automatic, continuous application of the lubricant.

For this purpose, a suitable lubrication gear is brought into contact with the drive gear or the rack.

The PU lubrication gear does not transmit any torque, but only transfers the lubricant to the toothing that is in contact.

The required relubrication quantities for different gears under different operating conditions can be found in the diagram below.

The prerequisite for the validity of the diagram is the use of the corresponding PU lubricating Pinion and a suitable gear lubricant such as F01, F02 or F03.

**Before using for the first time, the PU lubrication pinions must be filled with a suitable lubricant.**

# The PU-Lubrication-pinion

The lubrication-pinions consist of an open-cell polyurethane foam (temperature range  $-40\text{ }^{\circ}\text{C}$  .  $+ 120\text{ }^{\circ}\text{C}$ ) and are composed of several segments.

For the selection, a constructive decision must be made as to whether the lubrication gear, the rack or the drive gear should be lubricated.

It is preferably attached to the drive gear.

The open-cell polyurethane foam material used for the lubrication gears ensures that the teeth are optimally supplied over a very long period of time.

The material stores the lubricant and releases it again in the smallest metered quantities. Over-lubrication is avoided, as well as insufficient lubrication.

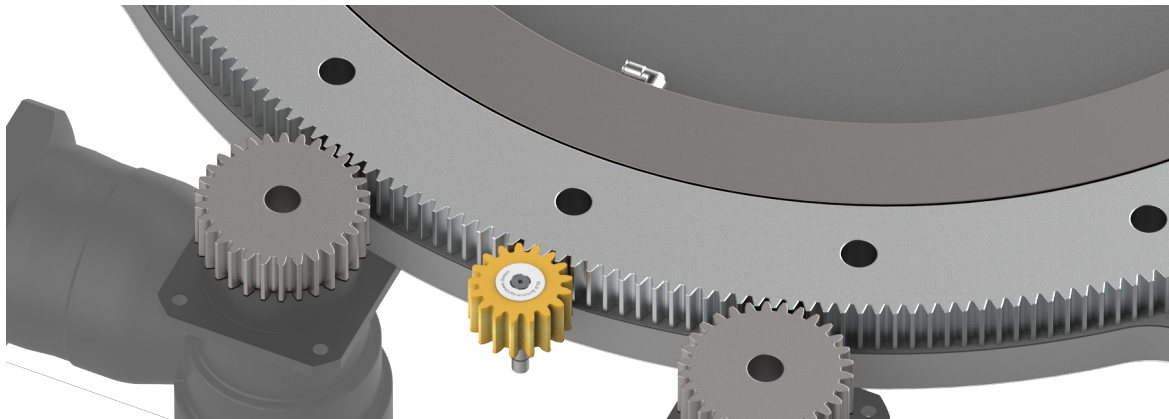

# Sets

## PU-Lubrication-pinion with axis, straight

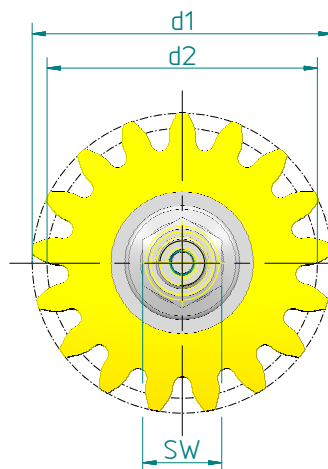
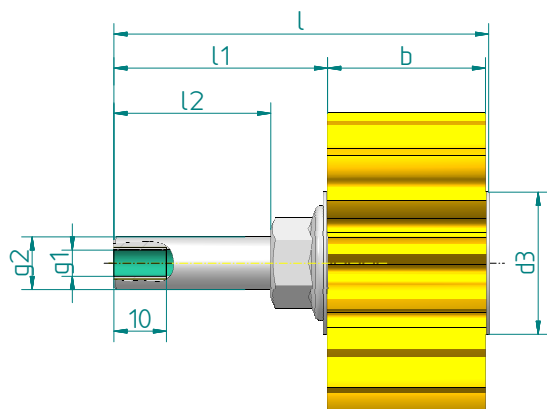

**Description:**  
 PU-Lubrication-pinion;  
 straight;  
 incl. sleeve bearing;  
 with straight axis  
 toothing according to DIN 867  
 pre-oiled with oil (H1 approval)

**Material:**  
 Pinion: open-cell PU foam;  
 axis: stainless Steel

module	z	b	d1	d2	l	l1	l2	g1	g2	d3	sw	part-no.
1,5	24	15,0	39	36	60,4	44,7	34	M6	M10	27	15	150-152-421
2	17	20,0	38	34	63,9	43,2	32,5	M6	M10	27	15	150-021-721
3	17	30,0	57	51	71,2	40,5	29,8	M6	M10	27	15	150-031-721
4	17	40,0	76	68	81,2	40,5	29,8	M6	M10	27	15	150-041-721
5	17	50,0	95	85	116,4	65,7	49,5	M10x1	M16	60	24	150-051-721
6	17	60,0	114	102	126,4	65,7	49,5	M10x1	M16	60	24	150-061-721
8	17	80,0	152	136	146,4	65,7	49,5	M10x1	M16	100	24	150-081-721
10	17	100,0	190	170	166,4	65,7	49,5	M10x1	M16	100	24	150-101-721

\*Alternatively also possible without H1 approval



# Sets

## PU-Lubrication-pinion with axis, right-angled

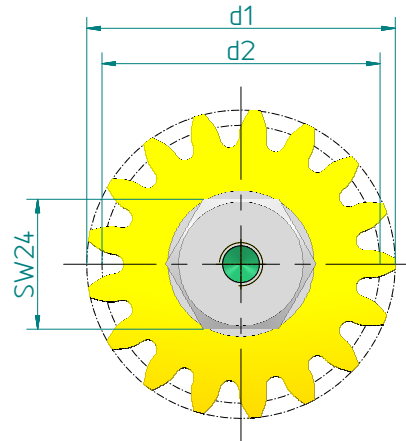
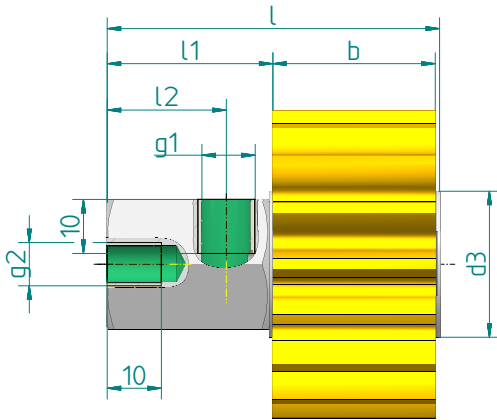

### Description:

PU-Lubrication-pinion;  
straight;  
incl. sleeve bearing;  
with angled axis  
toothing according to DIN 867  
pre-oiled with oil (H1 approval)

### Material:

Pinion: open-cell PU foam;  
axis: stainless Steel

module	z	b	d1	d2	l	l1	l2	g1	g2	d3	sw	part-no.
1,5	24	15,0	39	36	46,4	30,7	22	M10x1	M8	27	24	150-152-411
2	17	20,0	38	34	51,4	30,7	22	M10x1	M8	27	24	150-021-711
3	17	30,0	57	51	61,4	30,7	22	M10x1	M8	27	24	150-031-711
4	17	40,0	76	68	71,4	30,7	22	M10x1	M8	27	24	150-041-711
5	17	50,0	95	85	81,4	30,7	22	M10x1	M8	60	24	150-051-711
6	17	60,0	114	102	91,4	30,7	22	M10x1	M8	60	24	150-061-711
8	17	80,0	152	136	111,4	30,7	22	M10x1	M8	100	24	150-081-711
10	17	100,0	190	170	131,4	30,7	22	M10x1	M8	100	24	150-101-711

\*Alternatively also possible without H1 approval

# Sets

## PU-Lubrication-pinion RH with axis, straight

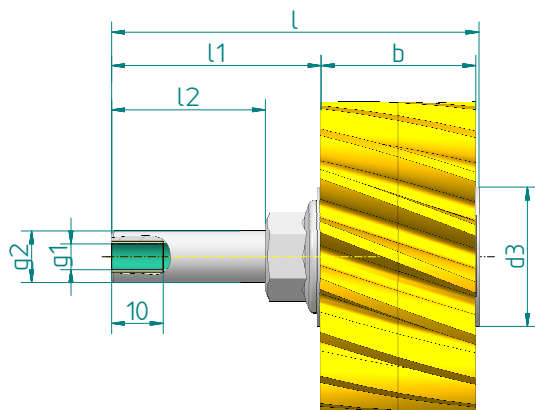

### Description:

PU-Lubrication-pinion;  
helical right;  
incl. sleeve bearing;  
with straight axis  
toothing according to DIN 867  
pre-oiled with oil (H1 approval)

### Material:

Pinion: open-cell PU foam;  
axis: stainless Steel

module	z	b	d1	d2	l	l1	l2	g1	g2	d3	sw	$\beta$	part-no.
1,5	24	15,0	41,2	38,2	60,4	44,7	34	M6	M10	27	15	19,53°	151-152-421
2	17	20,0	40,1	36,1	63,9	43,2	32,5	M6	M10	27	15	19,53°	151-021-721
3	17	30,0	60,1	54,1	71,2	40,5	29,8	M6	M10	27	15	19,53°	151-031-721
4	17	40,0	80,2	72,2	81,2	40,5	29,8	M6	M10	27	15	19,53°	151-041-721
5	17	50,0	100,2	90,2	116,4	65,7	49,5	M10x1	M16	60	24	19,53°	151-051-721
6	17	60,0	120,2	108,2	126,4	65,7	49,5	M10x1	M16	60	24	19,53°	151-061-721
8	17	80,0	160,3	144,3	146,4	65,7	49,5	M10x1	M16	100	24	19,53°	151-081-721
10	17	100,0	200,4	180,4	166,4	65,7	49,5	M10x1	M16	100	24	19,53°	151-101-721

\*Alternatively also possible without H1 approval

# Sets

## PU-Lubrication-pinion RH with axis, right-angled

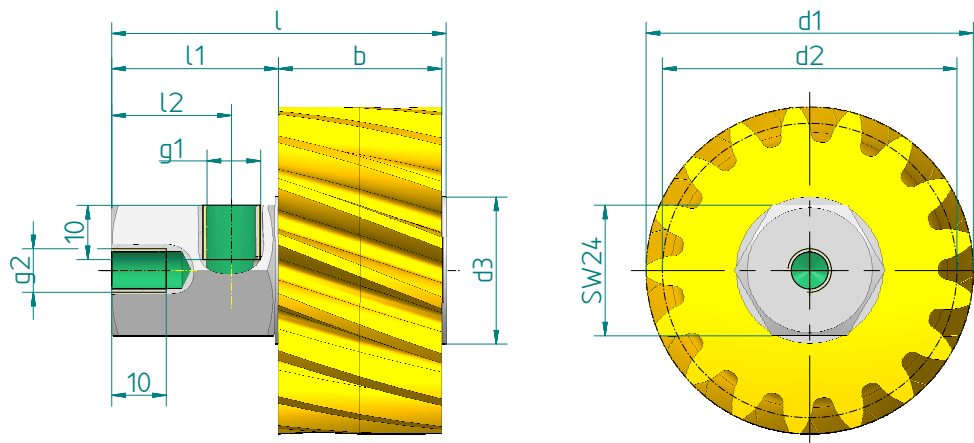

### Description:

PU-Lubrication-pinion;  
helical right;  
incl. sleeve bearing;  
with straight axis  
toothing according to DIN 867  
pre-oiled with oil (H1 approval)

### Material:

Pinion: open-cell PU foam;  
axis: stainless Steel

module	z	b	d1	d2	l	l1	l2	g1	g2	d3	sw	$\beta$	part-no.
1,5	24	15,0	41,2	38,2	46,4	30,7	22	M10x1	M8	27	15	19,53°	151-152-411
2	17	20,0	40,1	36,1	51,4	30,7	22	M10x1	M8	27	15	19,53°	151-021-711
3	17	30,0	60,1	54,1	61,4	30,7	22	M10x1	M8	27	15	19,53°	151-031-711
4	17	40,0	80,2	72,2	71,4	30,7	22	M10x1	M8	27	15	19,53°	151-041-711
5	17	50,0	100,2	90,2	81,4	30,7	22	M10x1	M8	60	24	19,53°	151-051-711
6	17	60,0	120,2	108,2	91,4	30,7	22	M10x1	M8	60	24	19,53°	151-061-711
8	17	80,0	160,3	144,3	111,4	30,7	22	M10x1	M8	100	24	19,53°	151-081-711
10	17	100,0	200,4	180,4	131,4	30,7	22	M10x1	M8	100	24	19,53°	151-101-711

\*Alternatively also possible without H1 approval

# Sets

## PU-Lubrication-pinion LH with axis, straight

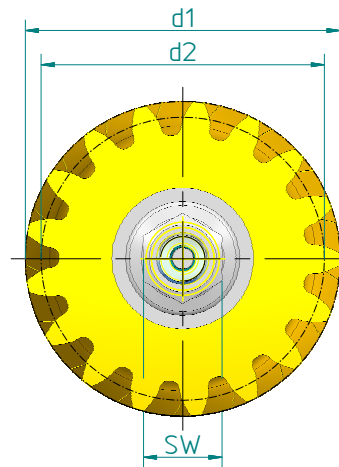
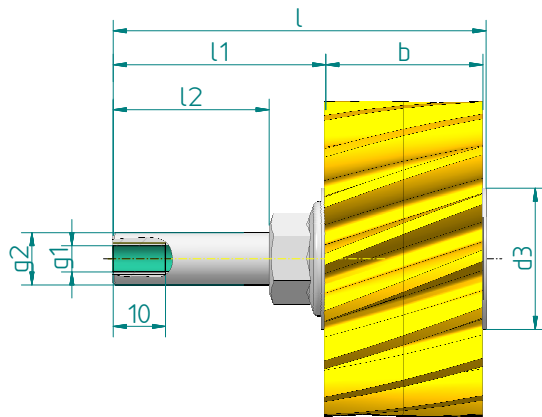

### Description:

PU-Lubrication-pinion;  
helical left;  
incl. sleeve bearing;  
with straight axis  
toothing according to DIN 867  
pre-oiled with oil (H1 approval)

### Material:

Pinion: open-cell PU foam;  
axis: stainless Steel

module	z	b	d1	d2	l	l1	l2	g1	g2	d3	sw	$\beta$	part-no.
1,5	24	15,0	41,2	38,2	60,4	44,7	34	M6	M10	27	15	19,53°	152-152-421
2	17	20,0	40,1	36,1	63,9	43,2	32,5	M6	M10	27	15	19,53°	152-021-721
3	17	30,0	60,1	54,1	71,2	40,5	29,8	M6	M10	27	15	19,53°	152-031-721
4	17	40,0	80,2	72,2	81,2	40,5	29,8	M6	M10	27	15	19,53°	152-041-721
5	17	50,0	100,2	90,2	116,4	65,7	49,5	M10x1	M16	60	24	19,53°	152-051-721
6	17	60,0	120,2	108,2	126,4	65,7	49,5	M10x1	M16	60	24	19,53°	152-061-721
8	17	80,0	160,3	144,3	146,4	65,7	49,5	M10x1	M16	100	24	19,53°	152-081-721
10	17	100,0	200,4	180,4	166,4	65,7	49,5	M10x1	M16	100	24	19,53°	152-101-721

\*Alternatively also possible without H1 approval

# Sets

## PU-Lubrication-pinion LH with axis, right-angled

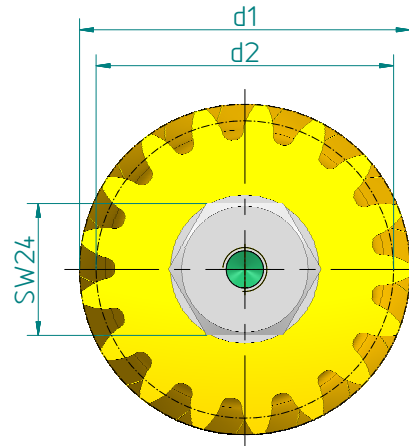
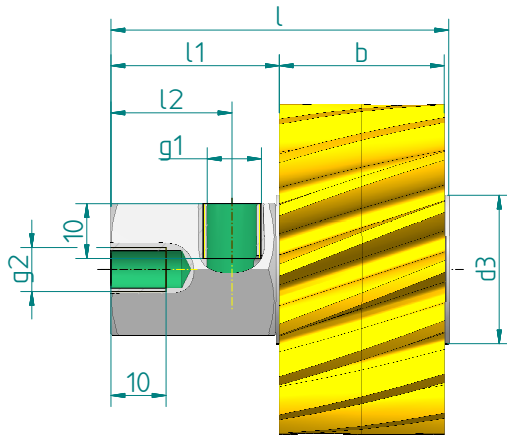

### Description:

PU-Lubrication-pinion;  
helical left;  
incl. sleeve bearing;  
with angled axis  
toothing according to DIN 867  
pre-oiled with oil (H1 approval)

### Material:

Pinion: open-cell PU foam;  
axis: stainless Steel

module	z	b	d1	d2	l	l1	l2	g1	g2	d3	sw	$\beta$	part-no.
1,5	24	15	41,2	38,2	46,4	30,6	22	M10x1	M8	27	24	19,53°	152-152-411
2	17	20	40,1	36,1	51,4	30,6	22	M10x1	M8	27	24	19,53°	152-021-711
3	17	30	60,1	54,1	61,4	30,6	22	M10x1	M8	27	24	19,53°	152-031-711
4	17	40	80,2	72,2	71,4	30,6	22	M10x1	M8	27	24	19,53°	152-041-711
5	17	50	100,2	90,2	81,4	30,6	22	M10x1	M8	60	24	19,53°	152-051-711
6	17	60	120,2	108,2	91,4	30,6	22	M10x1	M8	60	24	19,53°	152-061-711
8	17	80	160,3	144,3	111,4	30,6	22	M10x1	M8	60	24	19,53°	152-081-711
10	17	100	200,4	180,4	131,4	30,6	22	M10x1	M8	100	24	19,53°	152-101-711

\*Alternatively also possible without H1 approval

# Initial greasing of PU-lubrication pinions

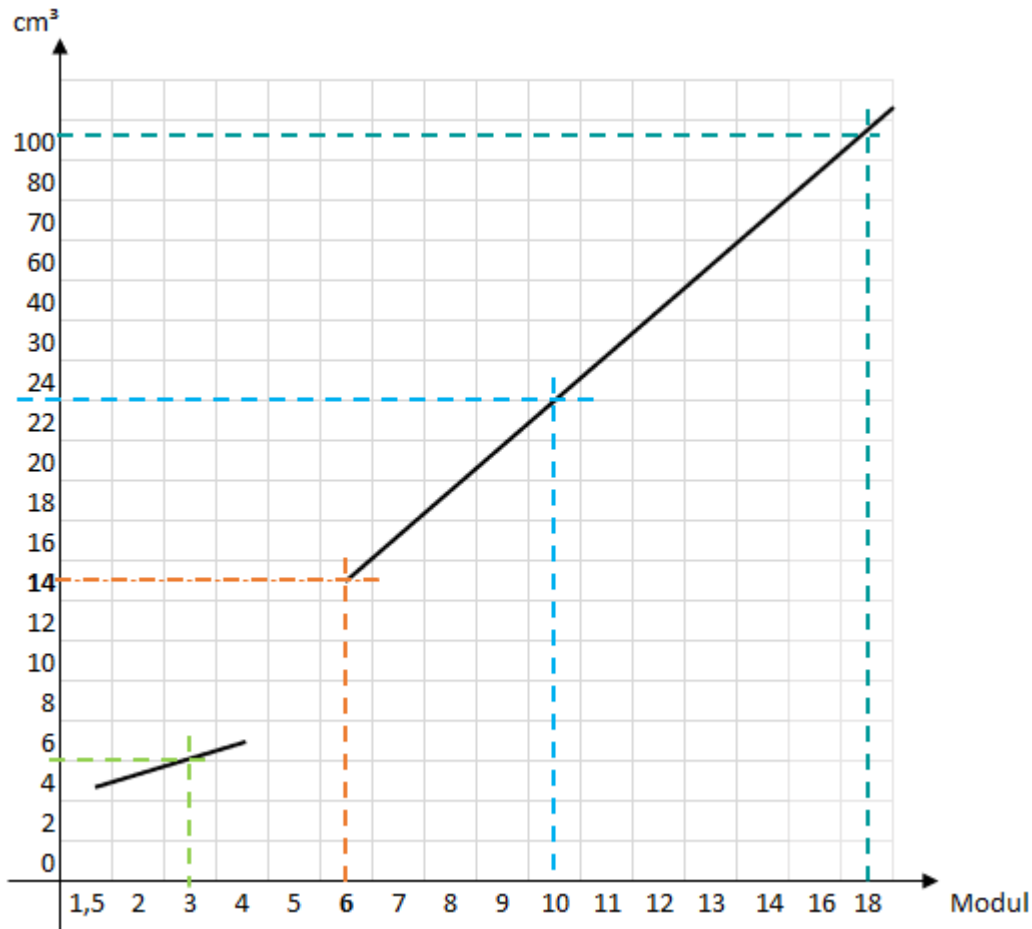

A suitable filling set for the initial greasing of the PU-lubrication pinions with lubricant can be found on page 90.

Module	1,5	2	3	4	5	6	7	8	9	10	11	12
Grease volume for initial greasing (cm <sup>3</sup> )	4	4	5	6	12	14	17	18	20	23	24	27
Number of pump strokes with hand grease gun	11	11	14	17	34	40	49	51	57	66	69	77
Number of pump strokes with pump	27	27	33	40	80	93	113	120	133	153	160	180

# The heart of every good lubrication!

Grease requirement when lubricating with PU-lubrication-pinions

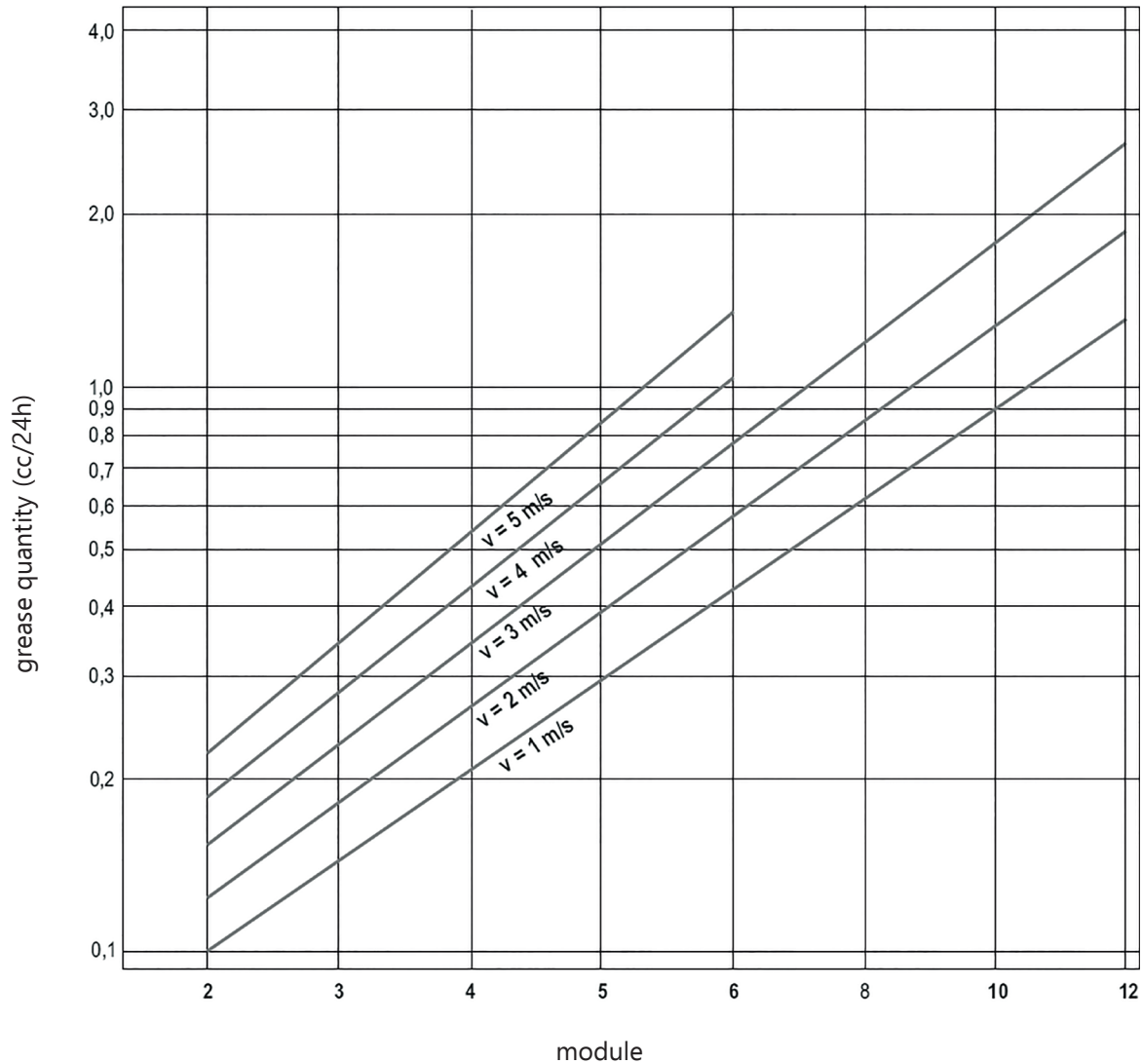

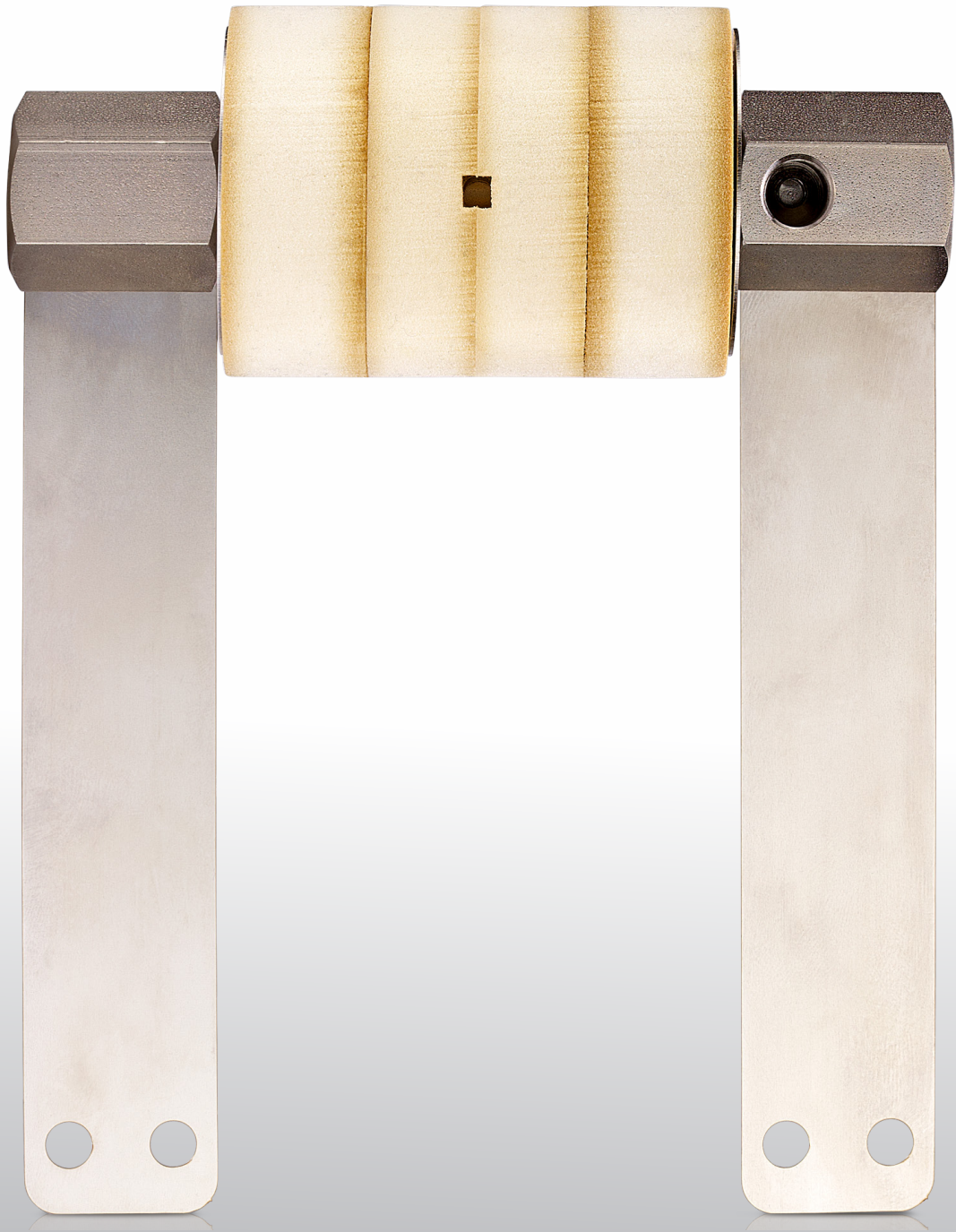



# PU-Lubrication-roller

The rolls of the PU-Lubrication-roller consist of an open-cell polyurethane foam (temperature range -30 °C . +120 °C) and are composed of several segments.

They are particularly suitable for relubricating rails for guides.

- + for grease lubrication
- + grease up to NLGI class 2
- + diameter up to 600 mm
- + freely selectable contours
- + very good emergency running properties
- + covers and enclosures on request
- + the PU-Lubrication-roller are provided with grooves for grease lubrication

# PU-Lubrication-roller for grease

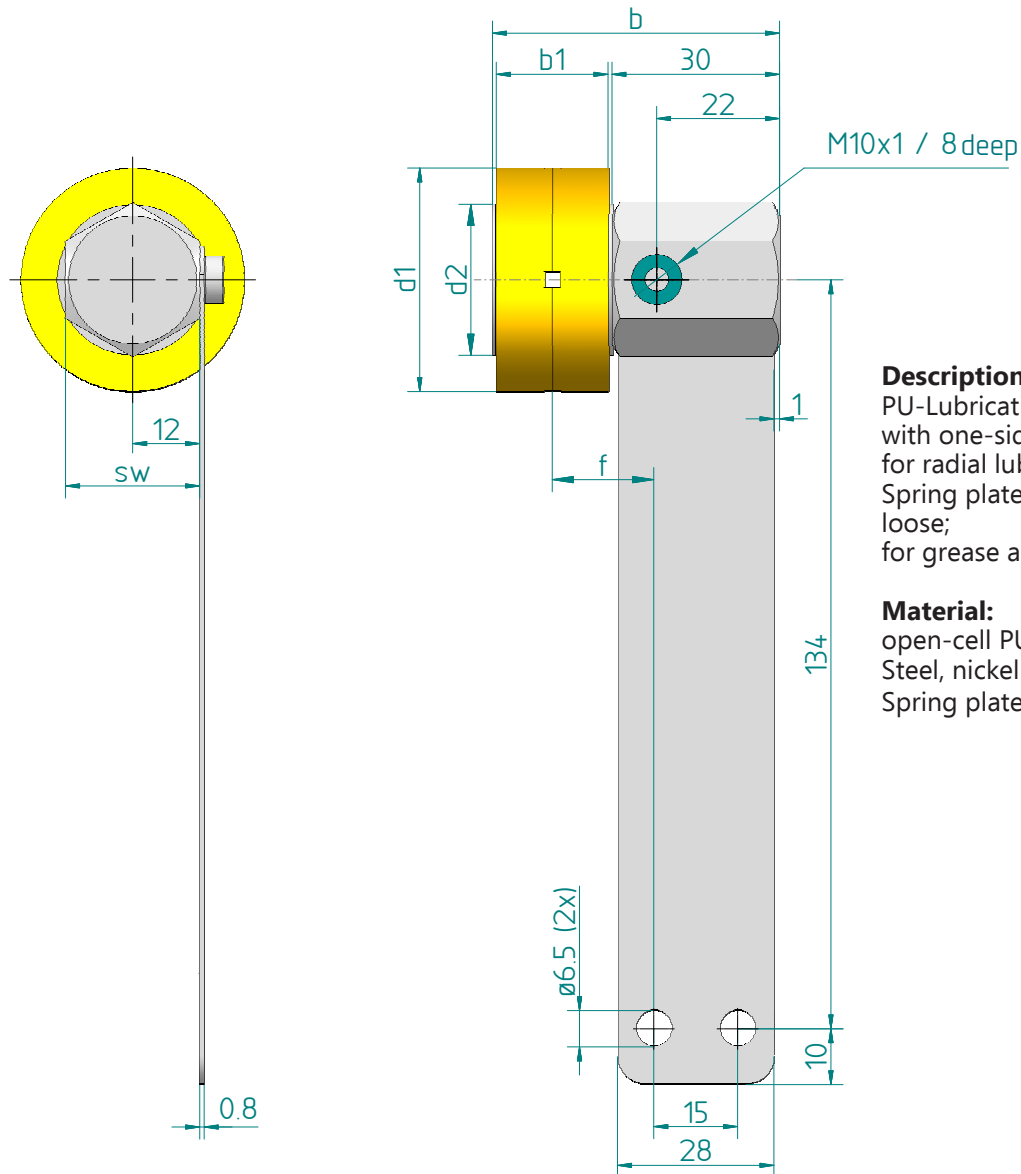

## Description:

PU-Lubrication-roller; sleeve bearing;  
with one-sided recording;  
for radial lubricant supply;  
Spring plate and screws supplied  
loose;  
for grease applications

## Material:

open-cell PU foam;  
Steel, nickel-plated;  
Spring plate in 1.4310

# Single-sided

b1	d1	b	d2	g1	part-no.
20	40	51,4	27	M10x1 10mm	127-020-403
24	40	55,4	27	M10x1 10mm	127-024-403
30	40	61,4	27	M10x1 10mm	127-030-403
40	40	71,4	27	M10x1 10mm	127-040-403
45	40	76,4	27	M10x1 10mm	127-045-403
50	65	81,4	45	M10x1 10mm	127-050-653
60	65	91,4	45	M10x1 10mm	127-060-653

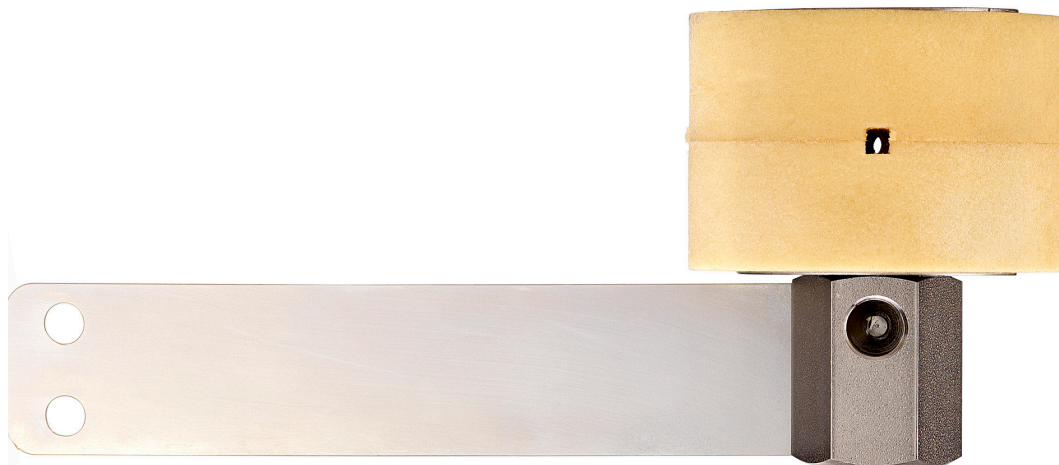

# PU-Lubrication-roller for grease

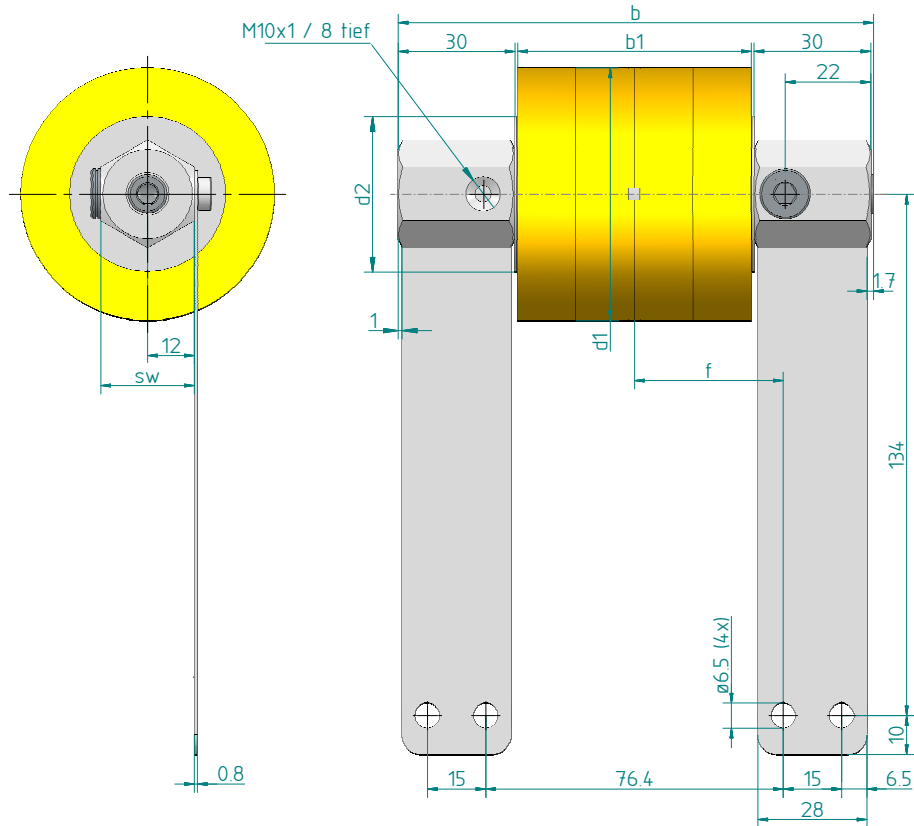

## Description:

PU-Lubrication-roller; sleeve bearing; with double-sided recording;  
for one-sided, radial lubricant supply;  
Spring plate and screws supplied loose;  
for grease applications

## Material:

open-cell PU foam;  
Steel, nickel-plated;  
Spring plate in 1.4310

## Double-sided

b1	d1	d2	b	g1	t	part-no.
60	65	40	121,4	M10x1 10 mm	0,8	127-060-654
70	65	40	131,4	M10x1 10 mm	0,8	127-070-654
80	65	40	141,4	M10x1 10 mm	0,8	127-080-654
90	65	40	151,4	M10x1 10 mm	0,8	127-090-654

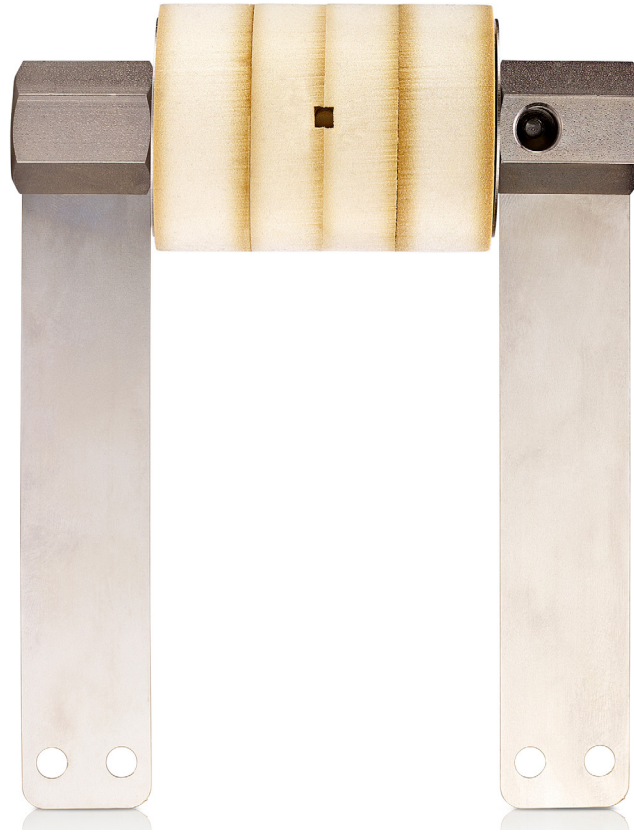



Oil lubrication is preferably used to lubricate plain and ball bearings. It is suitable for high speeds of the components to be lubricated.

In comparison to oil bath lubrication, an oil pump is integrated into this system.

This system is called automatic lubrication.

This ensures that the relevant bearing points are constantly supplied with the right lubricant and the precise quantity. However, this does not prevent the control of this system.

This type of lubrication reduces the level of contamination and extends bearing life.

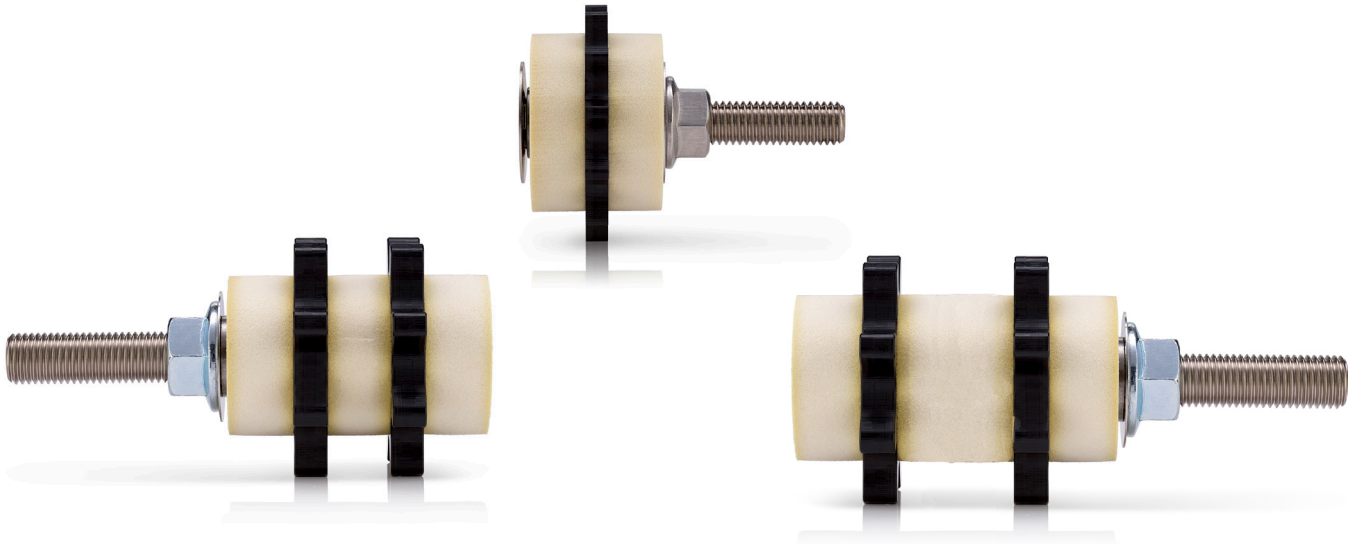

# Chain Lubrication

## PU-Lubrication-sprocket

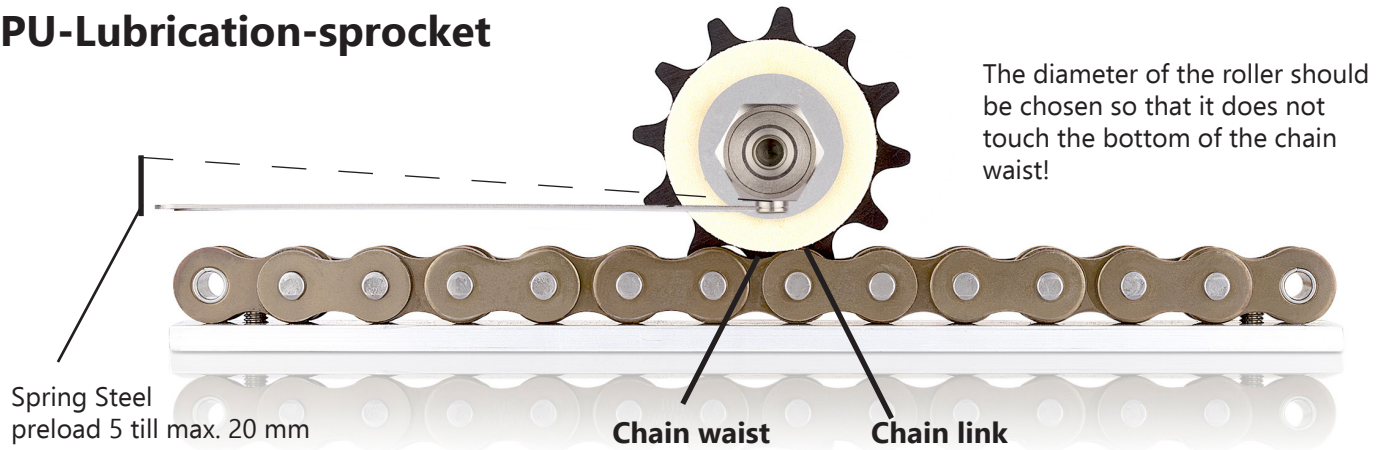

## PU-Lubrication-roller

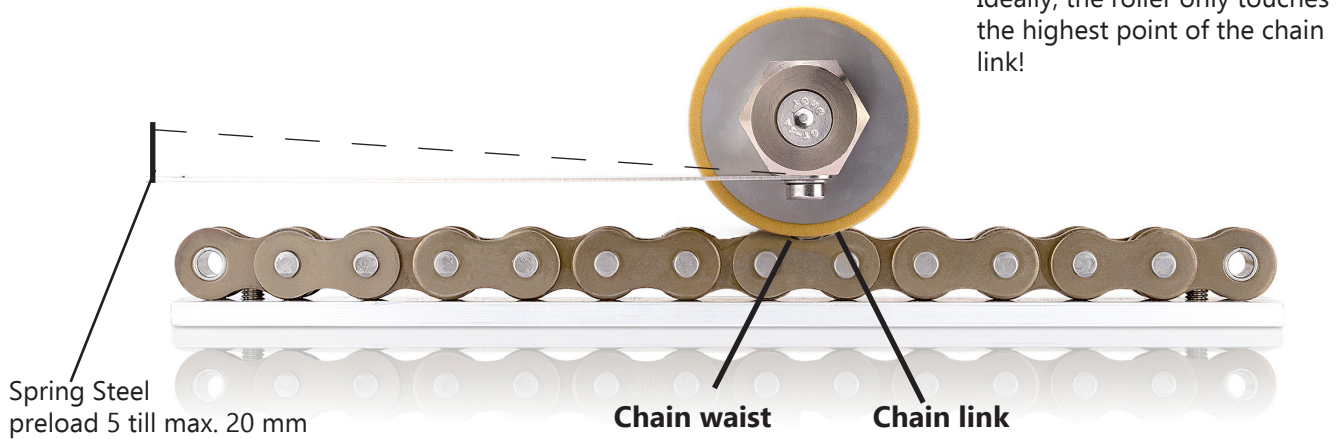



# PU-Lubrication-sprocket

The rollers made of open-cell PU foam transfer the lubricant selectively to the surface of the link plates of roller chains. The mechanical power to drive the rollers is ensured by a low-wear plastic Pinion.

The open-cell polyurethane foam material used for the lubricating gears ensures that the chains are optimally supplied over very long periods of time.

The material stores the lubricant and releases it again in very small dosages.

Over-lubrication is avoided, as is wear due to insufficient lubrication.

The PU-Lubrication-sprockets are available for simplex, duplex and triplex chains with and without spring Steel, depending on the size. The optimal contact pressure of the lubricating Pinion can be individually adjusted using a tensioning element. With the tensioning element, absorb also vibrations and shocks.

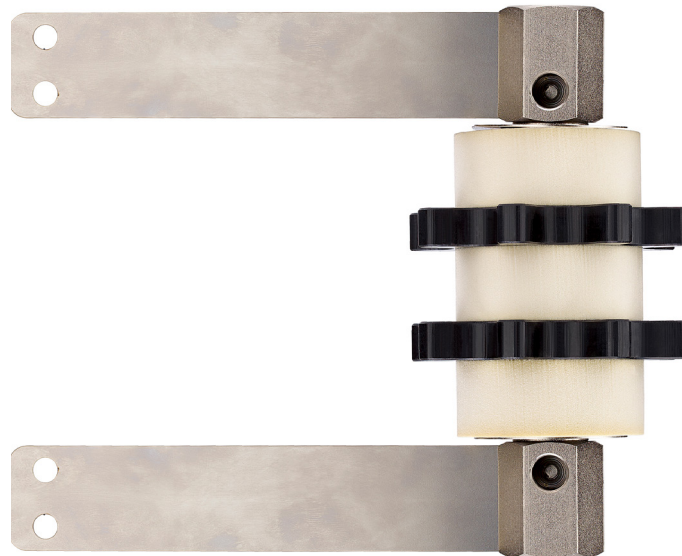

# PU-Lubrication-sprocket simplex - with axis

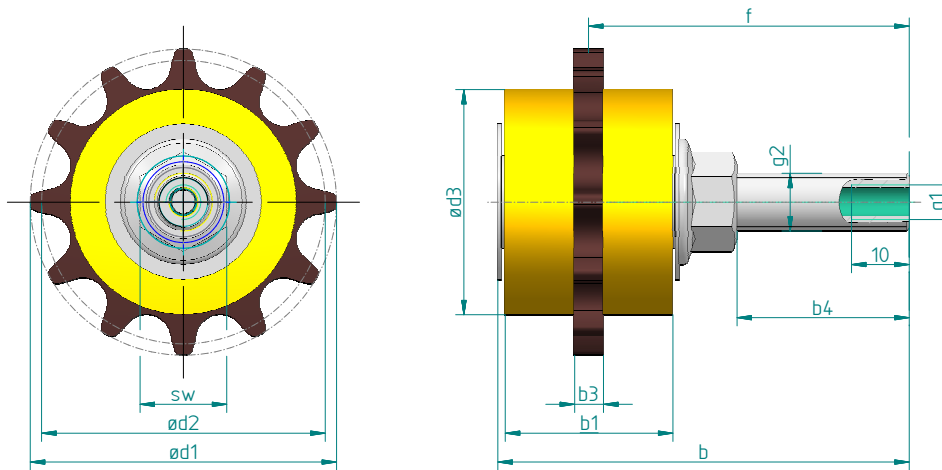

## Description:

PU-Lubrication-sprocket for simplex roller chain; mounted on straight axis; sleeve bearings;

## Material:

Sprocket: PA;  
Axis: nickel plated Steel;  
Roll: PU-foam;

**mounting position:**  
arbitrary

DIN 8187-1/8188-1	z	b	b1	d1	d2	d3	f	b3	b4	g1	g2	sw	part-no.
08B-1	12	71,2	29	53	49,1	39	55,5	5	30,0	M6	M10	15	136-201-012
10B-1	10	71,2	29	55	51,4	39	55,5	5	30,0	M6	M10	15	136-301-010
12B-1	8	71,2	29	55	49,8	36	55,5	5	30,0	M6	M10	15	136-401-008
16B-1	8	81,2	40	75	66,4	48	60,5	10	30,0	M6	M10	15	136-501-008
20B-1	8	116,4	50	90	83,0	59	90,7	10	49,1	M10x1	M16	24	136-601-008
24B-1	10	126,4	60	138	123,3	93	95,7	20	49,1	M10x1	M16	24	136-701-010
28B-1	8	146,4	80	140	116,2	81	105,7	20	49,1	M10x1	M16	24	136-801-008
32B-1	8	146,4	80	150	132,8	93	105,7	20	49,1	M10x1	M16	24	136-901-008

# PU-Lubrication-sprocket simplex - with spring Steel

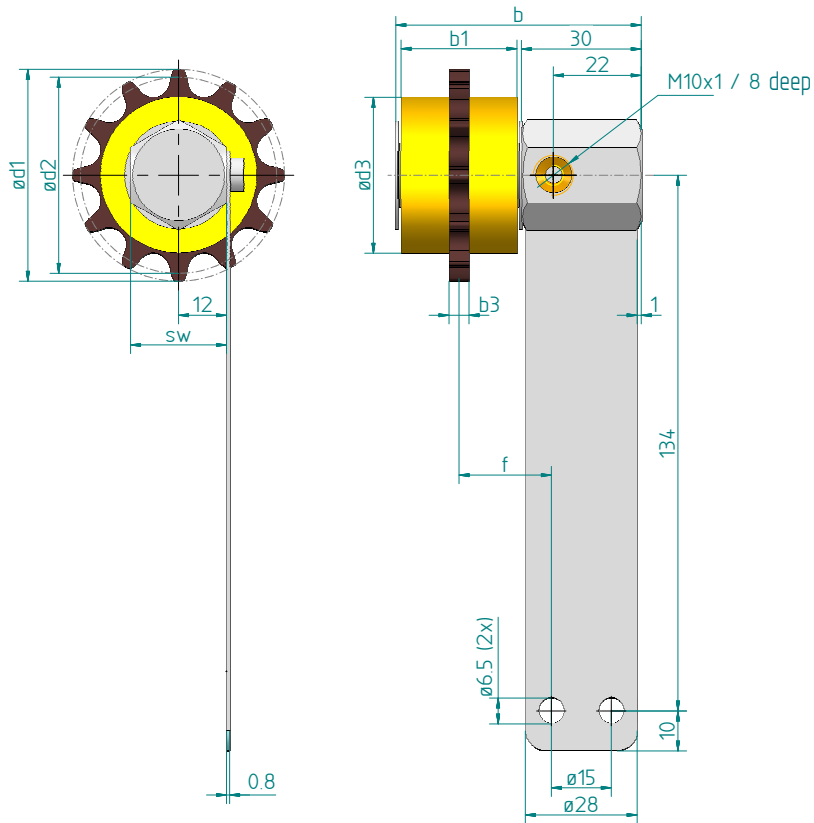

## Description:

PU-Lubrication-sprocket for simplex-roller chain; mounted on angled axis; with spring Steel; sleeve bearings;

## Material:

Sprocket: PA;  
Axis: nickel plated Steel;  
Roll: PU-foam;

## mounting position:

arbitrary

Spring Steel and screws enclosed loose.

DIN 8187-1 / 8188-1	z	b	b1	d1	d2	d3	b3	f	sw	part-no.
08B-1	12	61,4	29	53	49,1	39	5	23,2	24	136-201-112
10B-1	10	61,4	29	55	51,4	39	5	23,2	24	136-301-110
12B-1	8	61,4	29	55	49,8	36	5	23,2	24	136-401-108
16B-1	8	71,4	40	75	66,4	48	10	28,2	24	136-501-108
20B-1	8	81,4	50	90	83,0	59	10	33,2	24	136-601-108

# PU-Lubrication-sprocket simplex - angled axis and double spring Steel

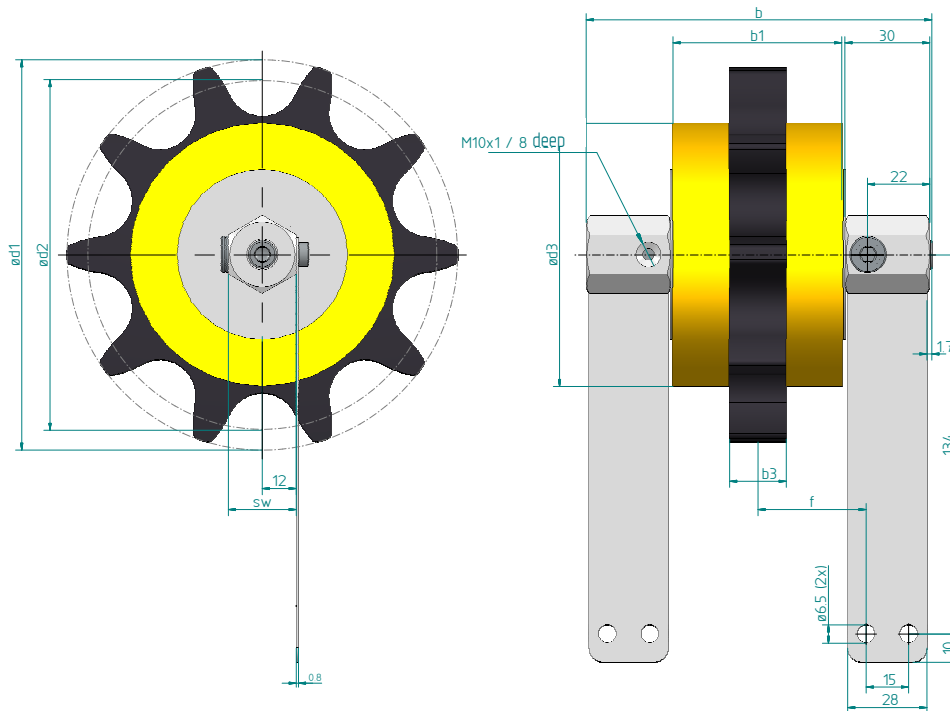

## Description:

PU-Lubrication-sprocket for simplex-roller chain; mounted on angled axis; with spring Steel; sleeve bearings;

## Material:

Sprocket: PA;  
Axis: nickel plated Steel;  
Roll: PU-foam;

## mounting position:

arbitrary

Spring Steel and screws enclosed loose.

DIN 8187-1 / 8188-1	z	b	b1	d1	d2	d3	b3	f	sw	part-no.
24B-1	10	122,1	60	138	123,3	93	20	38,2	24	136-701-110
28B-1	8	142,1	80	140	116,2	81	20	48,2	24	136-801-108
32B-1	8	142,1	80	150	132,8	93	20	48,2	24	136-901-108

# PU-Lubrication-sprocket duplex - straight axis

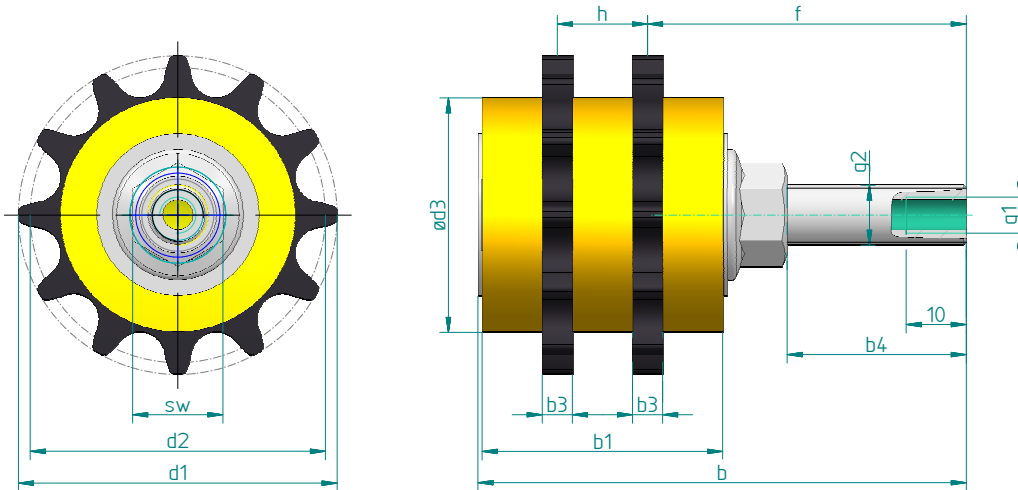

## Description:

PU-Lubrication-sprocket for duplex-roller chain; mounted on straight axis; sleeve bearings;

## Material:

Sprocket: PA;  
Axis: nickel plated Steel;  
Roll: PU-foam;

## mounting position:

arbitrary

DIN 8187-1/8188-1	z	b	b1	d1	d2	d3	f	h	b3	b4	g1	g2	sw	part-no.
08B-2	12	81,2	40	53	49,1	39	53,0	15	5	30,0	M6	M10	15	136-202-012
10B-2	10	81,2	40	55	51,4	39	53,0	15	5	30,0	M6	M10	15	136-302-010
12B-2	8	86,2	44	55	49,8	36	55,5	15	5	30,0	M6	M10	15	136-402-008
16B-2	8	146,4	80	75	66,4	48	90,7	30	10	49,1	M10x1	M16	24	136-502-008
20B-2	8	146,4	80	90	83,0	59	90,7	30	10	49,1	M10x1	M16	24	136-602-008
24B-2	10	166,4	100	138	123,3	93	90,7	50	10	49,1	M10x1	M16	24	136-702-010
28B-2	8	196,4	130	140	116,2	81	95,7	70	10	49,1	M10x1	M16	24	136-802-008
32B-2	8	196,4	130	150	132,8	93	95,7	70	10	49,1	M10x1	M16	24	136-902-008

# PU-Lubrication-sprocket duplex - angled axis and spring Steel

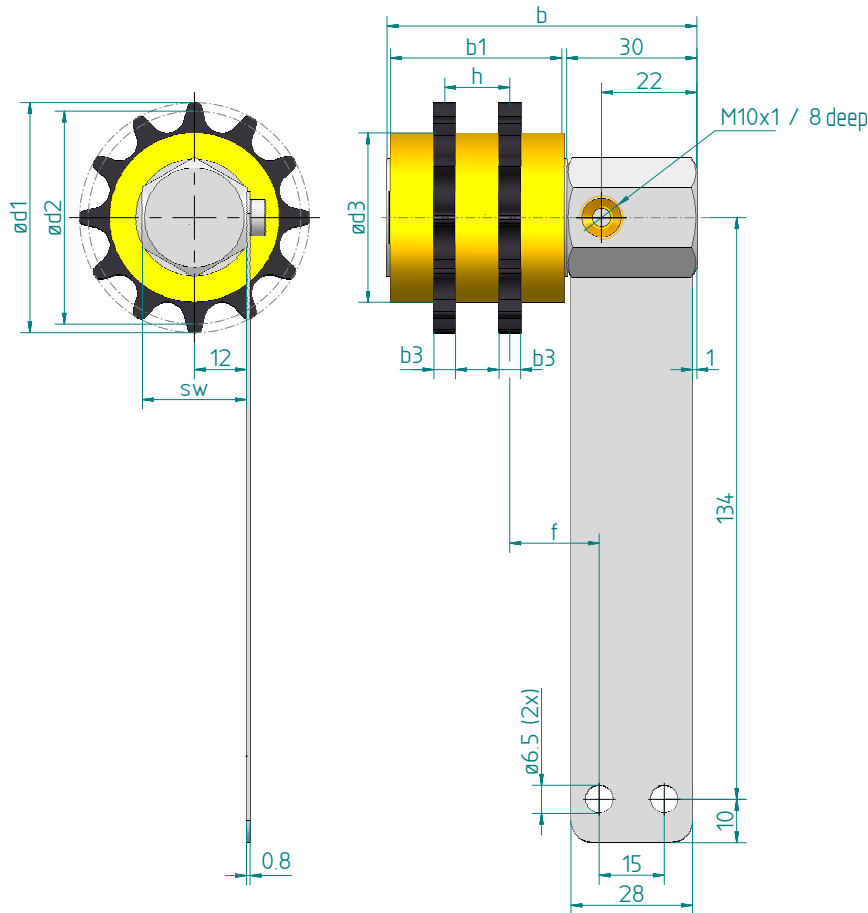

## Description:

PU-Lubrication-sprocket for duplex-roller chain; mounted on angled axis; with spring Steel; sleeve bearings;

## Material:

Sprocket: PA;  
Axis: nickel plated Steel;  
Roll: PU-foam;

## mounting position:

arbitrary

Spring Steel and screws enclosed loose.

DIN 8187-1/ 8188-1	z	b	b1	d1	d2	d3	f	h	b3	sw	part-no.
08B-2	12	71,4	40	53	49,1	39	20,7	15	5	24	136-202-112
10B-2	10	71,4	40	55	51,4	39	20,7	15	5	24	136-302-110
12B-2	8	76,4	44	55	49,8	36	23,2	15	5	24	136-402-108

# PU-Lubrication-sprocket duplex - angled axis and double spring Steel

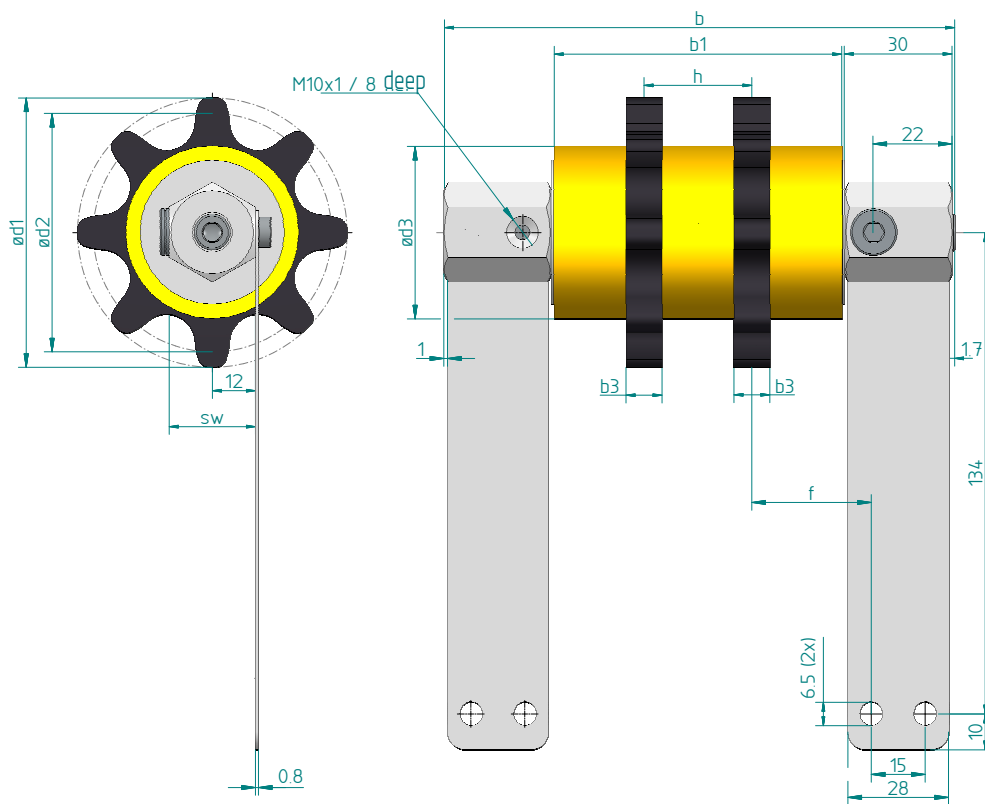

## Description:

PU-Lubrication-sprocket for duplex-roller chain; mounted on angled axis; with spring Steel; sleeve bearings;

## Material:

Sprocket: PA;  
Axis: nickel plated Steel;  
Roll: PU-foam;

## mounting position:

arbitrary

Spring Steel and screws enclosed loose.

DIN 8187-1/ 8188-1	z	b	b1	d1	d2	d3	f	h	b3	sw	part-no.
16B-2	8	142,1	80	75	66,4	48	33,2	30	10	24	136-502-108
20B-2	8	142,1	80	90	83,0	59	33,2	30	10	24	136-602-108
24B-2	10	162,1	100	138	123,3	93	33,2	50	10	24	136-702-110
28B-2	8	192,1	130	140	116,2	81	38,2	70	10	24	136-802-108
32B-2	8	192,1	130	150	132,8	93	38,2	70	10	24	136-902-108

# PU-Lubrication-sprocket triplex - angled axis and spring Steel

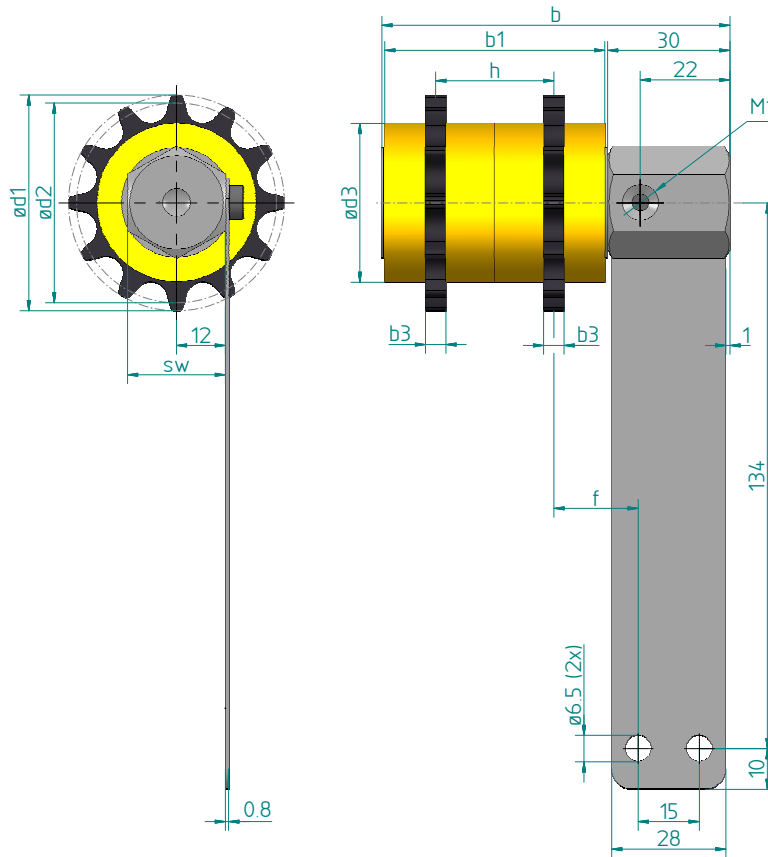

## Description:

PU-Lubrication-sprocket for triplex-roller chain; mounted on angled axis; with spring Steel; sleeve bearings;

## Material:

Sprocket: PA;  
Axis: nickel plated Steel;  
Roll: PU-foam;

## mounting position:

horizontal  
(vertical mounting position on request)

Spring Steel and screws enclosed loose.

DIN 8187-1/ 8188-1	z	b	b1	d1	d2	d3	f	h	b3	sw	part-no.
08B-3	12	85,4	54	53	49,1	39	20,7	29	5	24	136-203-112
10B-3	10	91,4	59	55	51,4	39	23,2	30	5	24	136-303-110



# PU-Lubrication-sprocket triplex - angled axis and double spring Steel

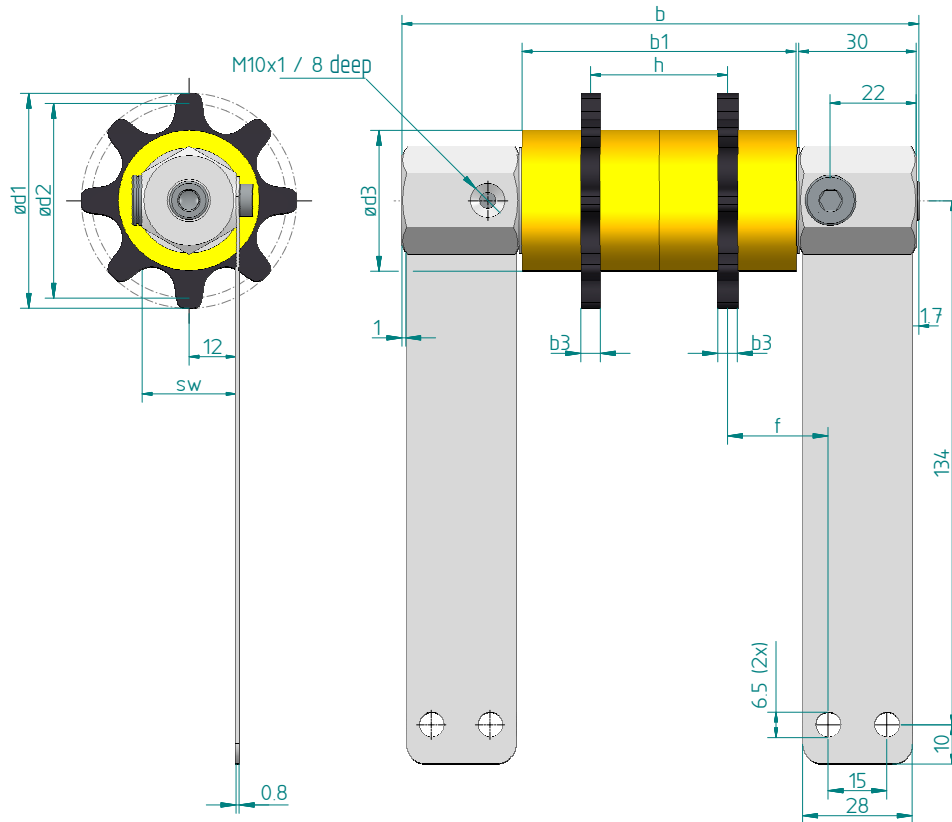

## Description:

PU-Lubrication-sprocket for triplex-roller chain; mounted on angled axis; with spring Steel; sleeve bearings;

## Material:

Sprocket: PA;  
Axis: nickel plated Steel;  
Roll: PU-foam;

## mounting position:

arbitrary

Spring Steel and screws enclosed loose.

DIN 8187-1 / 8188-1	z	b	b1	d1	d2	d3	f	h	b3	sw	part-no.
12B-3	8	132,1	70	55	49,8	36	25,7	35	5	24	136-403-108*
16B-3	8	162,1	100	75	66,4	48	28,2	60	10	24	136-503-108
20B-3	8	182,1	120	90	83,0	59	33,2	70	10	24	136-603-108
24B-3	10	212,7	150	138	123,3	93	33,5	100	10	24	136-703-110
28B-3	8	262,7	200	140	116,2	81	43,5	130	10	24	136-803-108
32B-3	8	262,7	200	150	132,8	93	43,5	130	10	24	136-903-108

\*only horizontal mounting position possible (vertical mounting position on request)

# PU-Lubrication-sprocket steel

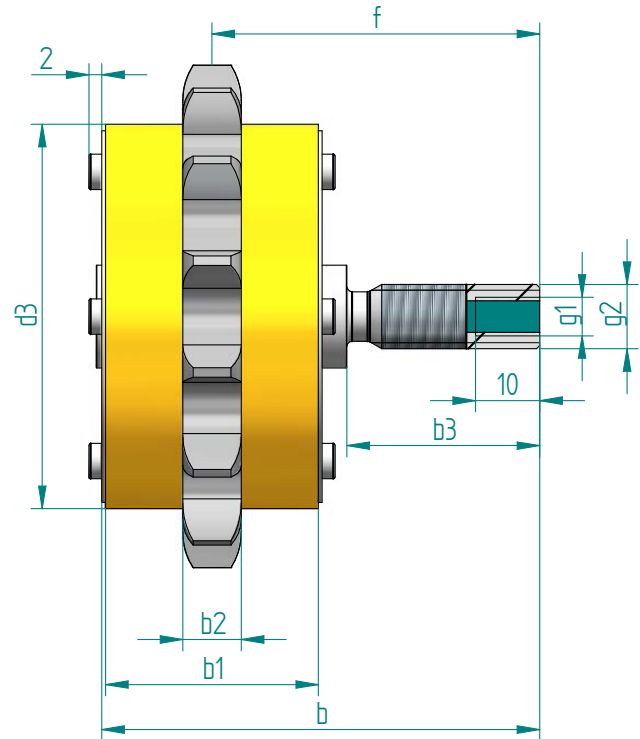
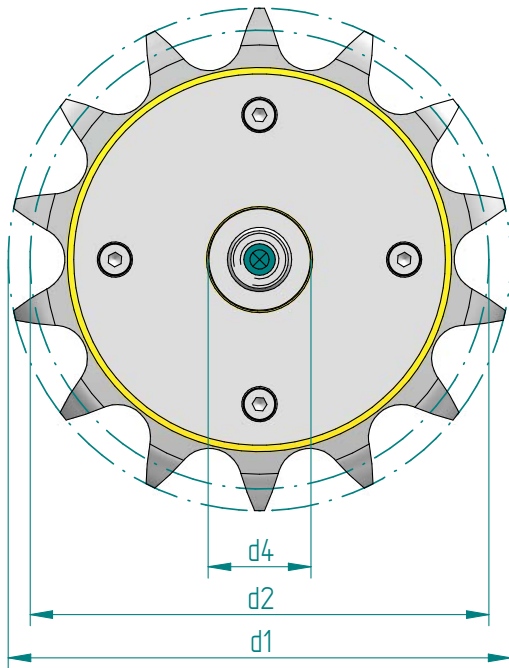

For high speeds  
from 2 m/s with roller bearings

Typ	z	b	b1	d1	d2	d3	f	b3	b4	g1	g2	d4	Part-No.
10B-1	14	67,55	33,1	78,2	71,34	59,8	51	9,1	30	M6	M10	16	136-311-014
12B-1	13	69,15	35,1	87,8	79,59	66,2	51	11,1	30	M6	M10	16	136-411-013
16B-1	12	100,3	40,2	109,7	98,14	79	79,6	16,2	49,1	M10x1	M16	20	136-511-012
20B-1	13	114,2	48,5	147,7	132,67	100	89,35	18,5	49,1	M10x1	M16	25	136-611-013

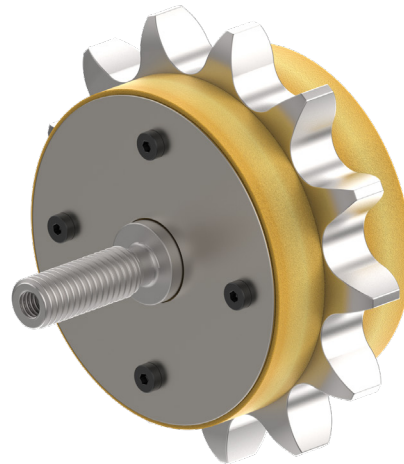
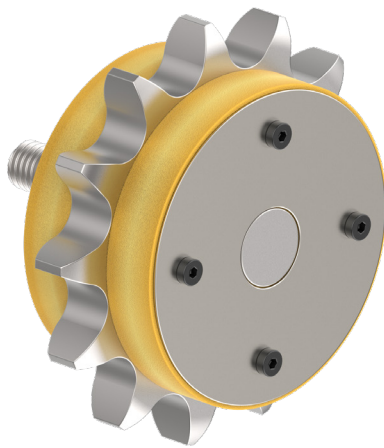

# PU-Lubrication-roller for oil

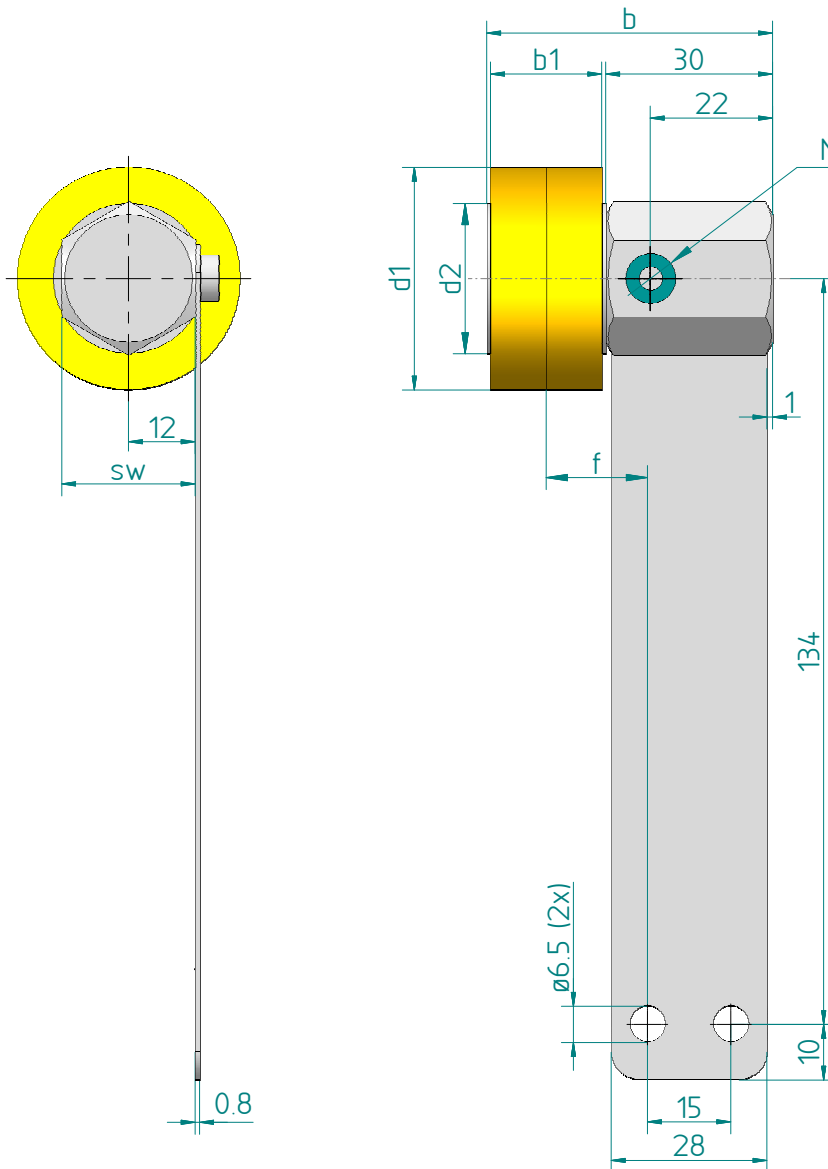

## Description:

PU-Lubrication-roller; sleeve bearings; with one-sided recording; for radial (angled) lubricant supply; on spring Steel mounted; oil applications

## Material:

Roll: open-cell PU foam;  
axis: Steel, nickel-plated;  
Spring Steel: 1.4310

## Mounting position:

horizontal

## Single-sided

b1	d1	b	d2	g1	part-no.
20	40	51,4	27	M10x1 10mm	137-020-403
24	40	55,4	27	M10x1 10mm	137-024-403
30	40	61,4	27	M10x1 10mm	137-030-403
40	40	71,4	27	M10x1 10mm	137-040-403
45	40	76,4	27	M10x1 10mm	137-045-403
50	65	81,4	45	M10x1 10mm	137-050-653
60	65	91,4	45	M10x1 10mm	137-060-653



# PU-Lubrication-roller for oil

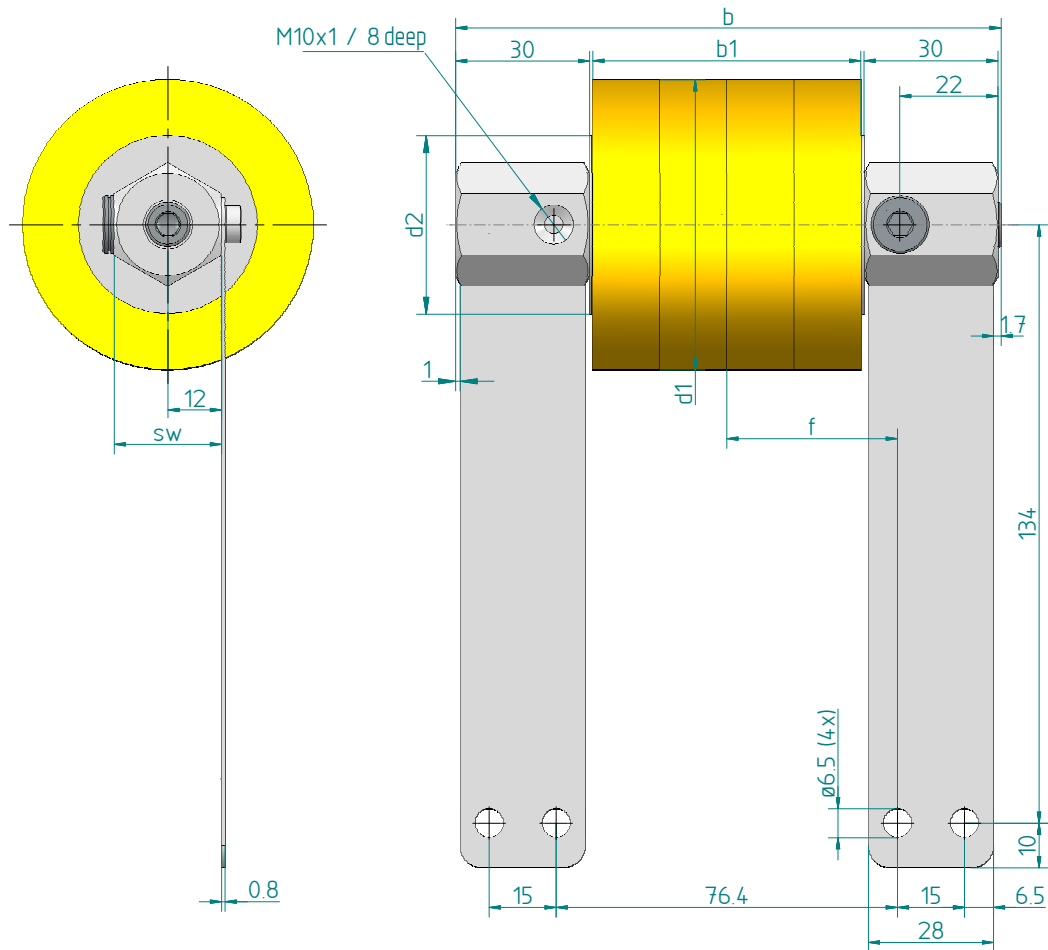

## Description:

PU-Lubrication-roller; sleeve bearings; with double-sided recording; for one-sided, radial (angled) lubricant supply; on spring Steel mounted; oil applications

## Material:

Roll: open-cell PU foam;  
axis: Steel, nickel-plated;  
Spring Steel: 1.4310

## Mounting position:

horizontal

## Double-sided

b1	d1	d2	b	g1	t	part-no.
60	65	40	121,4	M10x1 10mm	0,8	137-060-654
70	65	40	131,4	M10x1 10mm	0,8	137-070-654
80	65	40	141,4	M10x1 10mm	0,8	137-080-654
90	65	40	151,4	M10x1 10mm	0,8	137-090-654

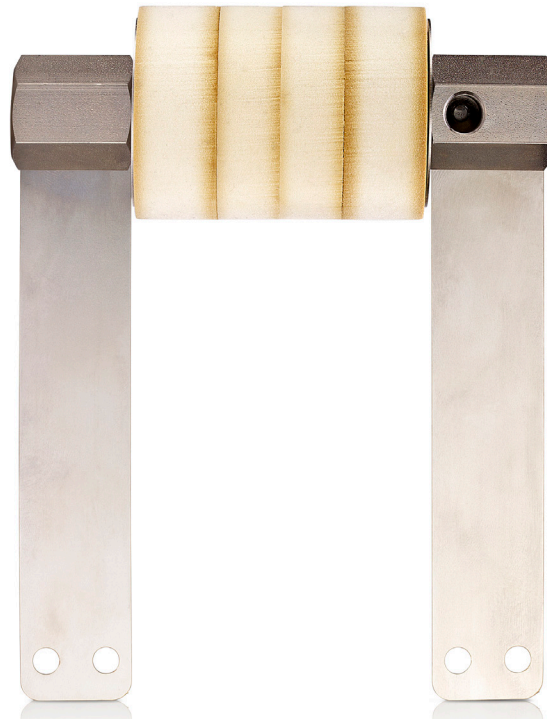

# PU-Lubrication-roller for accumulating conveyor chains angled axis with spring Steel

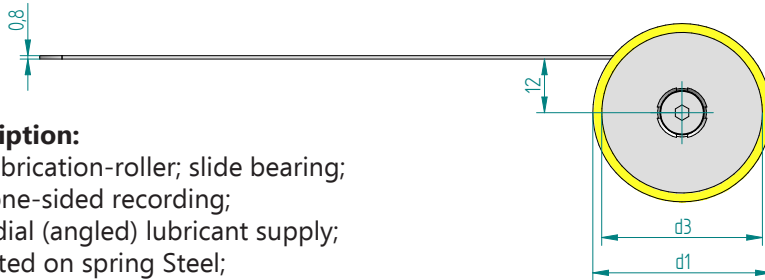
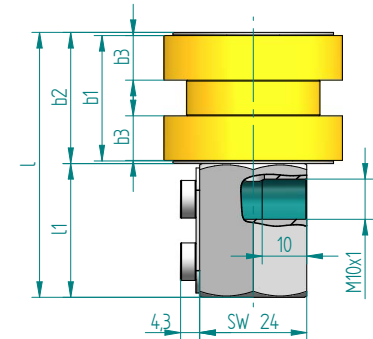
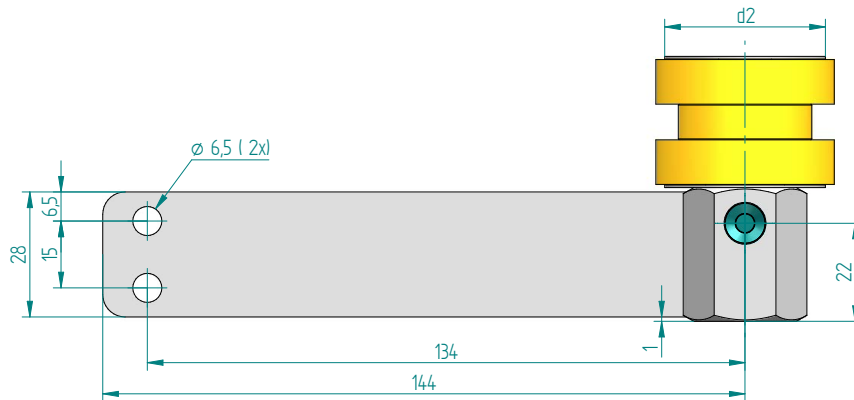

## Description:

PU-Lubrication-roller; slide bearing;  
with one-sided recording;  
for radial (angled) lubricant supply;  
mounted on spring Steel;  
Oil applications

## Material:

Role: open-cell PU foam;  
Axis: stainless Steel;  
Spring plate: 1.4310

## Mounting position:

horizontal

Spring Steel enclosed lose.

division	b1	b2	b3	d1	d2	d3	l	l1	part-no.
1/2"	28	29,4	10	40	29,9	36	59,4	30	137-028-403
3/4"	32	33,4	10	52	33,4	45	63,4	30	137-032-523
1"	38	39,4	10	59	33,9	45	69,4	30	137-038-593



# PU-Lubrication-roller for accumulating conveyor chains straight axis

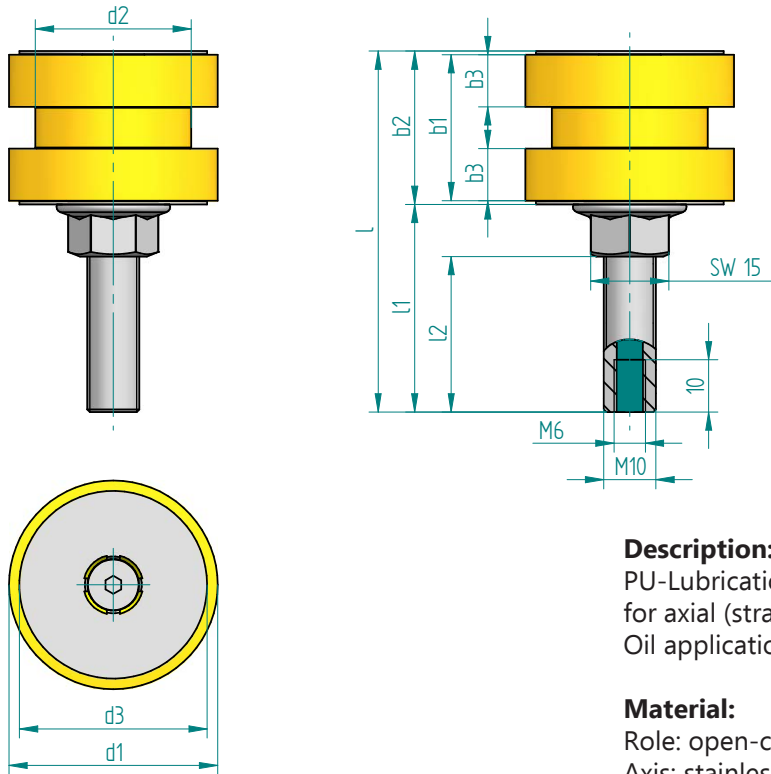

## Description:

PU-Lubrication-roller; slide bearing;  
for axial (straight) lubricant supply;  
Oil applications

## Material:

Role: open-cell PU foam;  
Axis: stainless Steel;

## Mounting position:

horizontal

division	b1	b2	b3	d1	d2	d3	d4	l	l1	l2	part-no.
1/2"	28	29,4	10	40	29,9	36	16	69,2	39,8	29,8	137-028-406
3/4"	32	32,2	10	52	33,4	45	28	73,2	39,8	29,8	137-032-526
1"	38	38,2	10	59	33,9	45	38,5	79,2	39,8	29,8	137-038-596



# Accesories

Complete the lubrication system in your system with our accessories consisting of tubes, batteries, holders and hose connectors.

We attach great importance to only using the best products.  
In this way we ensure that your system continues to run for a long time.

- + flexible
- + durable
- + high-quality
- + european manufacturing

# Tubes, empty for grease

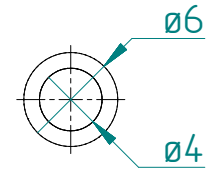
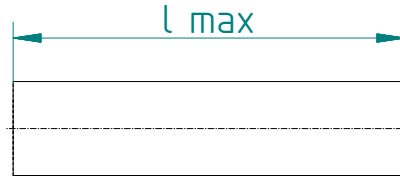

## Description:

Tube empty or with lubricant pre-filled;  
different lengths and diameters  
max. pressure 90 bar (at 20 ° C)

## Material:

PA; black



Suitable for drag chains

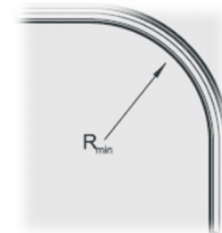

Smallest bending radius:  
 $R_{min} = 30 \text{ mm}$

Tube	d1	d2	l max.	Description	part-no.
empty	4	2,5	25 m	Tube black; Sold by the meter	134-004-003
	6	4	2,5 m	Tube black; 2,5 m length	134-024-001
	6	4	5 m	Tube black; 5 m length	134-054-001
	6	4	10 m	Tube black; 10 m length	134-104-001
	6	4	25 m	Tube black; 25 m length	134-254-001
	8	5	50 m	Tube black; Sold by the meter	134-004-005
accessories					part-no.
tube cutter					134-002-002

# Tubes for oil

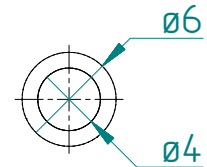
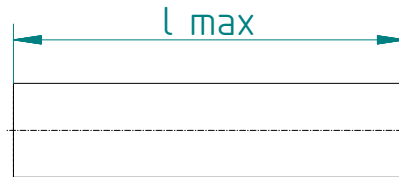

drag chain suitable

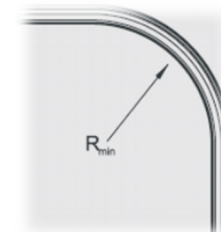

Smallest bending radius:  
 $R_{\min} = 30 \text{ mm}$

## Description:

Tube pre-filled with lubricant; (only OE1)

## Material:

PA; black ; transparent only for oil

lubricant	d1	d2	l max.	good to know	part-no.
OE1	6	4	15 m	tube, black; by meter	134-003-051
empty	6	3	50 m	tube, transparent; by meter	134-004-002

## notice:

tubes empty (transparent tube)

Exception: tube pre-filled with OE1 (black tube)

# Mounting bracket for applicators

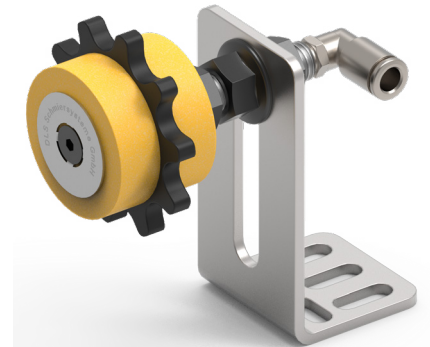
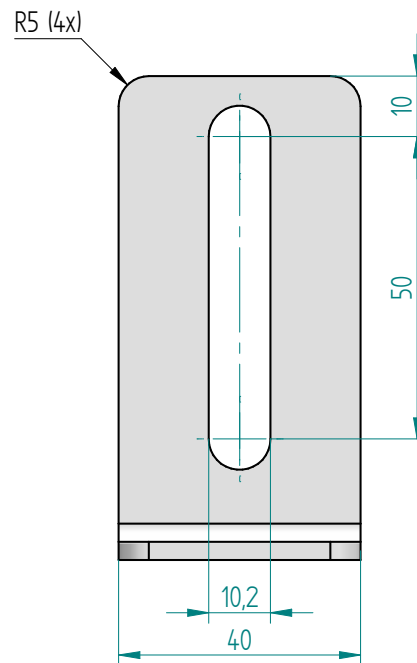
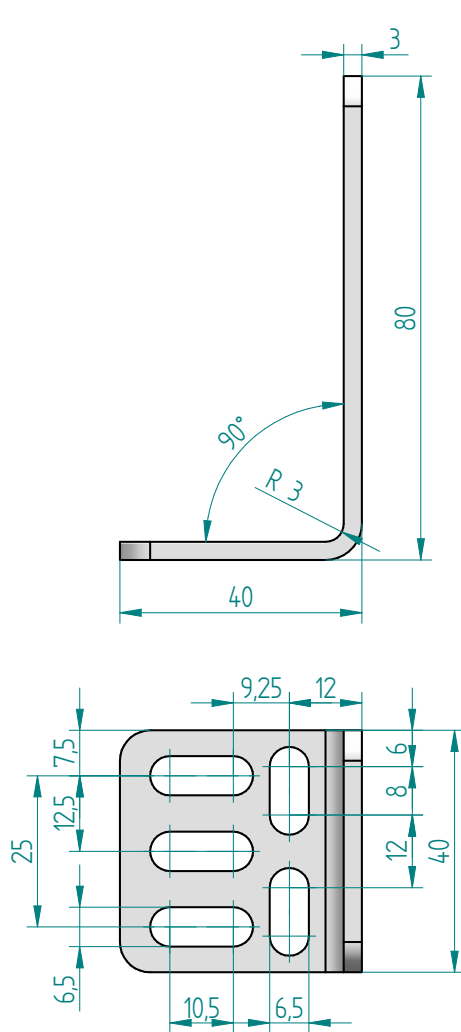

## Description:

mounting bracket 40/80; Slot for M10; Material: stainless Steel; for mounting lubricating gears and lubricating rollers with a diameter of up to 80 mm;

## Partnumber:

134-002-038

# Mounting bracket for applicators

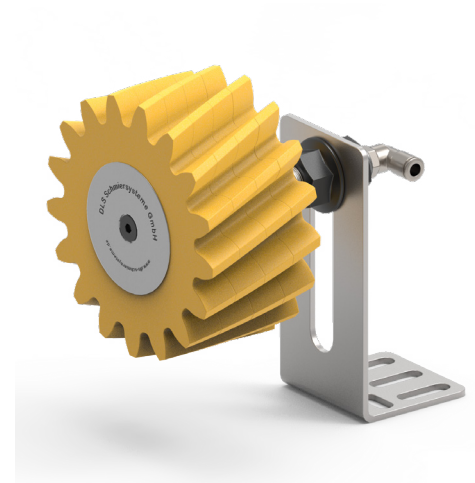
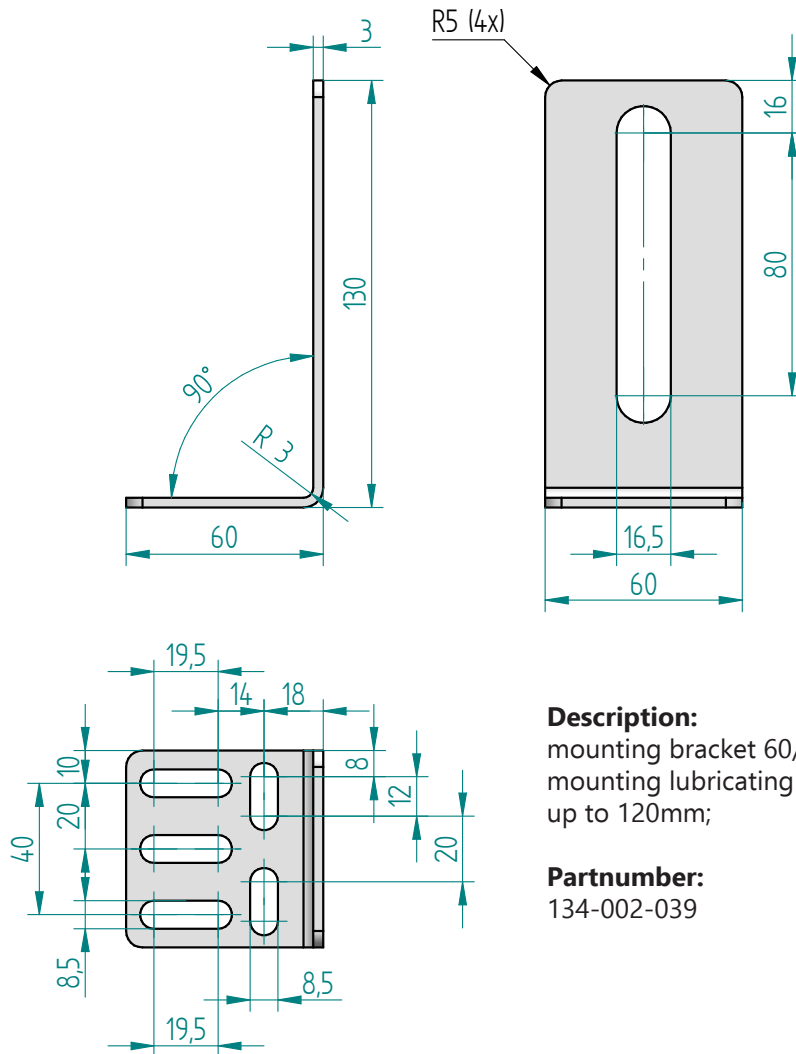

## Description:

mounting bracket 60/130; Slot for M16; Material: stainless Steel; for mounting lubricating gears and lubricating rollers with a diameter of up to 120mm;

## Partnumber:

134-002-039

# Hand grease guns Self-filling for tubes



Abb.: 134-002-033



Abb.: 134-002-034

## Sets for filling tubes:

With the sets offered here, you also have the option of filling tubes with diameters 6 or 8 yourself.

Filling quantity	Set content	part-no.
400 cc	1x Manual grease gun Lube Shuttle	134-002-033
	1x Tube connector; straight; thread M10x1; tube 6; sw=11; isw=4; type A; (134-000-011)	
500 cc	1x Tube connector; straight; tube 6 to tube 8; type A; max. pressure 16 bar, (134-000-105)	134-002-034
	1x Manual grease gun System-Reiner	
	1x Tube connector; straight; thread M10x1; tube 6; sw=11; isw=4; type A (134-000-011)	
	1x Tube connector; straight; tube 6 to tube 8; type A; max. pressure 16 bar, (134-000-105)	



# Hand grease guns

## Initial lubrication of PU-Lubrication-pinion



**100cc cartridges  
filled with F01 or F03**

filling amount	set content	Part-No.
100 cm <sup>3</sup>	Filling pump 100 cm <sup>3</sup> , individually	134-002-005
100 cm <sup>3</sup>	Set for initial greasing consisting of: - Hand grease gun for 100 cm <sup>3</sup> cartridges - Tube connector, straight - High-pressure tube 6x4, empty	134-002-043

You will find suitable cartridges with our lubricants F01 and F03



# Tube connectors

**Application:**

pluggable connection with the tubes

**Features:**

- sealing at the connection point with integrated O-rings
- easy assembly of the tubes
- all straight tube connectors with additional hexagon socket
- Further technical features can be found on the drawings at [www.dls-schmiersysteme.de](http://www.dls-schmiersysteme.de)

# Tube connectors

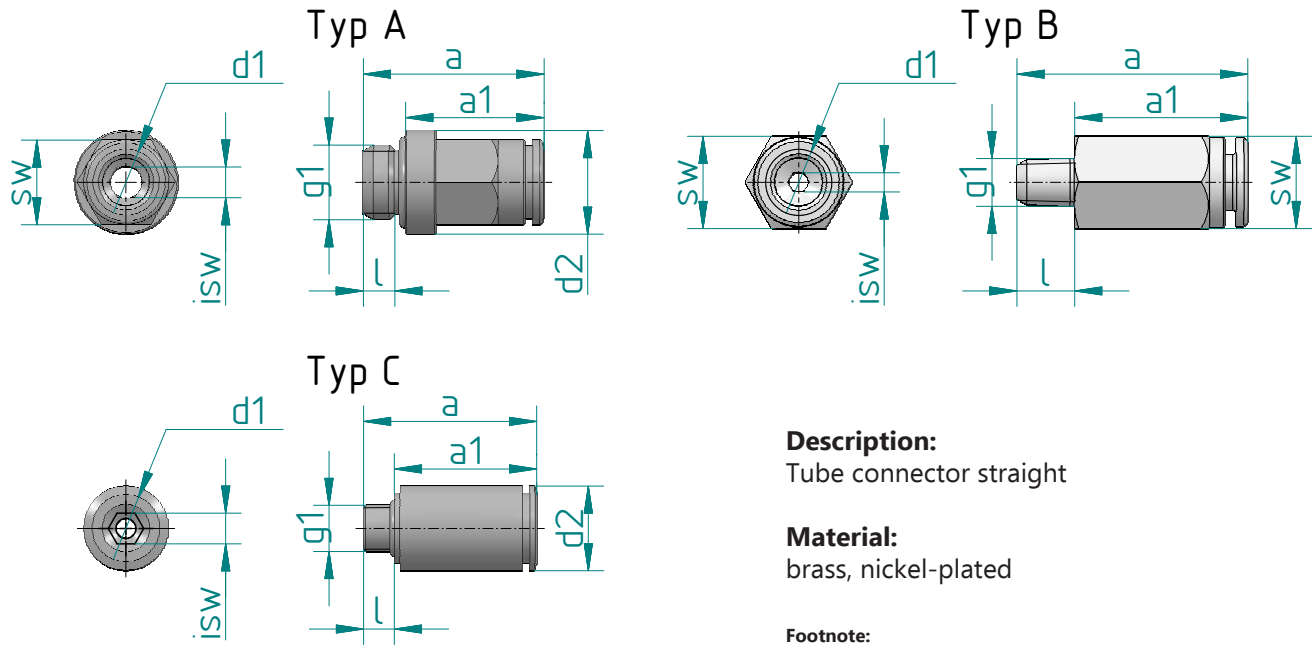

**Description:**  
Tube connector straight

**Material:**  
brass, nickel-plated

**Footnote:**  
Type A - cylindrical thread with O-ring seal  
Type B - conical thread without O-ring seal  
Type C - hexagon socket

## - straight version

d1	g1		Typ	d2	a	a1	l	SW	ISK	Part-No.
4	M3	DIN 13-1	C	9	21,3	16,3	5	-	1,5	134-000-017
4	M5	DIN 13-1	C	9	20,5	16,5	4	-	2,5	134-000-016
4	M6x0,75	DIN 13-2	C	8,8	20	15,5	4,5	-	2,5	134-000-009
4	M6	DIN 13-1	C	8,8	20,5	16	4,5	-	2,5	134-000-006
4	G1/8	ISO 228-1	A	13,5	19	13	6	12	2,5	134-000-012
6	M5	DIN 13-1	C	11	22	18	4	-	2,5	134-000-015
6	M6x0,75	DIN 13-2	C	11,8	22,5	18	4,5	-	2,5	134-000-010
6	M6 keg.	DIN 158-1	B	11,7	30	22,5	7,5	12	2,5	134-000-014
6	M6	DIN 13-1	C	11,8	22,5	18	4,5	-	2,5	134-000-001
6	M8x1 keg.	DIN 158-1	B	11	25,8	17,8	8	11	4	134-000-005
6	M10x1	DIN 13-3	A	13,5	21	15	6	12	4	134-000-011
6	G1/8	ISO 228-1	A	13,5	21	15	6	12	4	134-000-002
6	G1/4	ISO 228-1	A	16,4	22	15	7	15	4	134-000-004
6	R1/8 BSPT	DIN 2999	B	10,2	24,9	17	7,9	13	4	134-000-003
8	M10x1	DIN 13-2	A	13	26,5	19,5	6	13	5	134-000-019
8	G1/8	ISO 228-1	A	13	26,5	20,5	6	13	5	134-000-008
8	G1/4	ISO 228-1	A	17	23,5	17	6,5	13	6	134-000-018
8	M6	DIN 13-1	A	13	27,2	20,2	7	13	3	134-000-020

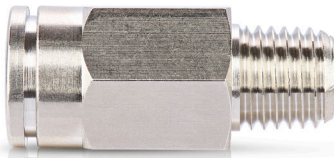

# Tube connectors

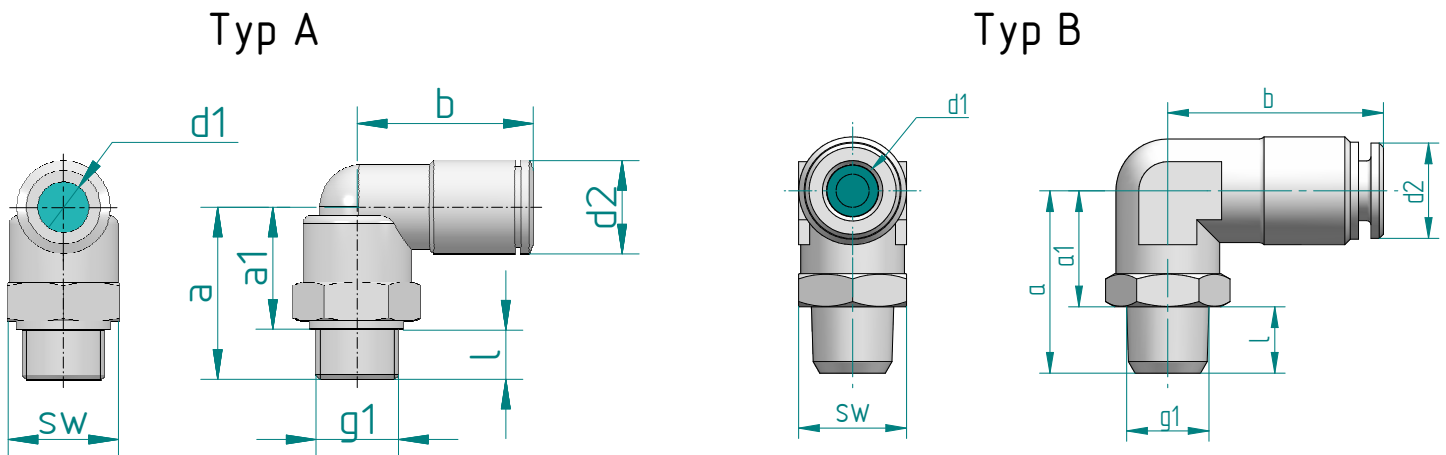

**Description:**

Tube connector right-angled;  
360° rotatable

**Material:**

brass, nickel-plated

**Footnote:**

Type A - cylindrical thread with O-ring seal  
Type B - conical thread without O-ring seal  
Type C - hexagon socket

## - right-angled version

d1	g1		Typ	d2	a	a1	b	l	SW	Part-No.
4	M3	DIN 13-1	A	9,1	16	11	18,2	5	6	134-001-021
4	M5	DIN 13-1	A	9	14,8	10,8	18	4	9	134-001-020
4	M6x0,75 k	DIN 158-1	B	9	13,5	7,5	17,5	6	8	134-001-004
4	M6x0,75	DIN 13-2	A	9	17,5	13	17,5	4,5	9	134-001-011
4	M6	DIN13-1	A	9	18	13	17,5	5	9	134-001-007
4	M10x1	DIN 13-2	A	9	20,5	14,5	17,5	6	12	134-001-005
4	G1/8	ISO 228-1	A	9	20,5	14,5	17,5	6	12	134-001-018
6	M5	DIN 13-1	A	11	14,8	10,8	21	4	9	134-001-019
6	M6	DIN 13-1	A	12,7	19	14	20	5	10	134-001-001
6	M6x0,75	DIN 13-2	A	12,7	19	14,5	20	4,5	10	134-001-012
6	M6 keg	DIN 158-1	B	12,8	25,3	19,3	22,5	6	11	134-001-014
6	M8x1 keg	DIN 158-1	B	12,7	20,5	13,5	20	7	10	134-001-010
6	M10x1	DIN 13-2	A	12,7	21	15	20	6	12	134-001-006
6	R1/8 keg.	DIN 2999-5	B	13	22	14	26	8	13	134-001-016
6	G1/8	ISO 228-1	A	12,7	21	15	20	6	12	134-001-002
6	G1/4	ISO 228-1	A	12,7	23	16	20	7	15	134-001-009
8	G1/8	ISO 228-1	A	13	20,3	14,3	24	6	13	134-001-024
8	G1/4	ISO 228-1	A	13	23,3	16,8	23,5	6,5	13	134-001-022
8	M6	DIN 13-1	A	13	19,5	14,5	23,5	5	13	134-001-025



# Tube connectors with non-return valve

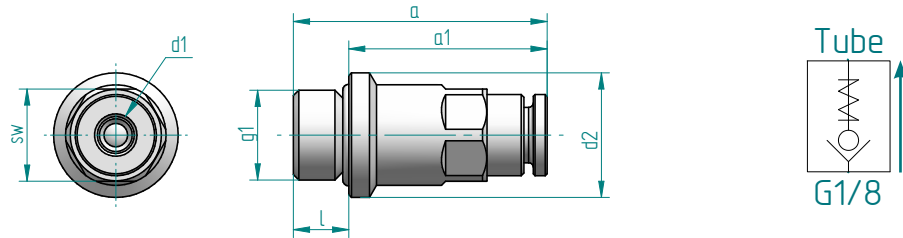

## Description:

Tube connector with integrated non-return valve; straight/angled; 360° rotatable;

## Material:

Nickel-plated brass; Gasket: NBR

d1	g1	d2	a	a1	b	l	sw	Part-No.
6	G1/8	13,5	27	21	-	6	12	134-000-114
4	G1/8	13,5	27,5	21,5	-	6	10	134-000-115



# Connections & reductions

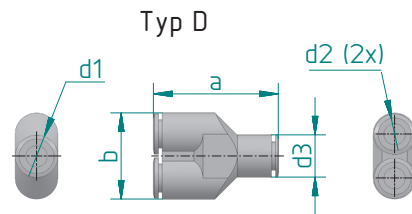
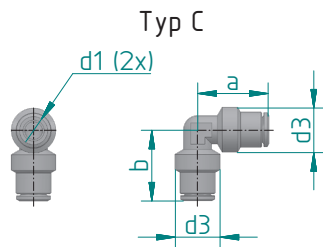
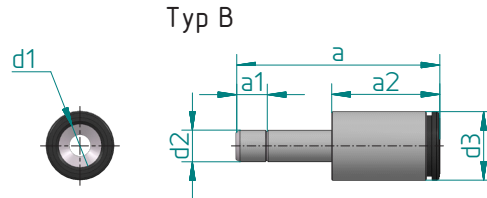
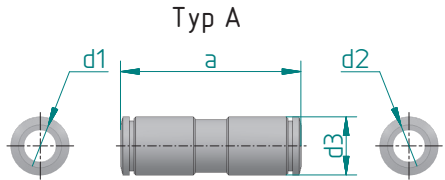

**Description:**  
Connections and reductions;  
straight or right-angled

**Material:**  
brass, nickel-plated;

Typ	d1	d2	d3	a	a1	a2	b	Part-No.
A	4	4	9,6	29	-	--	--	134-000-111
A	6	4	11	33,5	-	--	--	134-000-106
A	6	6	12	34	-	--	--	134-000-104
A	6	8	13	39	-	--	--	134-000-105
A	8	8	13	38	-	--	--	134-000-112
B	4	6	9	30,5	5,1	12,5	--	134-000-110
B	6	4	13	36	6,3	22	--	134-000-109
B	8	6	13	38,5	11,6	20,5	--	134-000-108
C	4	4	9	17,5	-	--	17,5	134-001-106
C	6	6	12,7	20	-	--	20	134-001-104
D	6	6	12	39	-	--	24,5	134-002-000
D	8	8	14	44	--	--	28,5	134-002-023



# Fittings

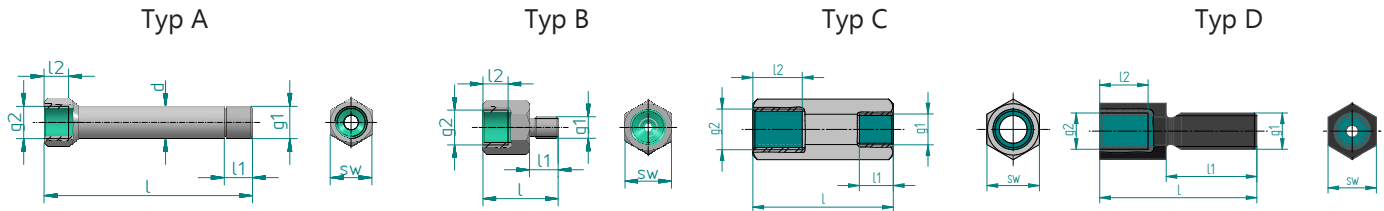

Typ	g1	g2	l	l1	l2	d	sw	material	Part-No.
A	G1/8	G1/8	50	12	13	14	17	Nickel-plated brass	134-000-703
A	G1/4	G1/4	85	11,5	10	13	17	Galvanized steel	134-000-701
A	G1/4	G1/4	104	10	10	13	17	Galvanized steel	134-000-702
A	G1/4	G1/4	122	13,5	10	14	17	Steel, nickel-plated	134-000-712
A	M6x1 (keg)	M6	57,5	7,5	8	6	9	Galvanized steel	134-000-715
C	G1/4	M10x1	45,5	11	16	-	17	stainless steel	134-000-713
B	M4	M3	16	6	6	-	6	Nickel-plated brass	134-000-707
B	M4	M6	18,5	6,5	7	-	9	Nickel-plated brass	134-000-708
B	M6	M10x1	21	8	7	-	13	stainless steel	134-000-704
B	M6	G1/8	21	8	7	-	13	Nickel-plated brass	134-000-705
B	M8	M6	19,2	11,2	7,5	-	10	Nickel-plated brass	134-000-706
B	M8	G1/4	24	10	8	-	17	Nickel-plated brass	134-000-710
B	M10x1	G1/4	24	10	8	-	17	Nickel-plated brass	134-000-711
B	G1/8	G1/4	35	7	12	13	17	Steel, nickel-plated	134-000-700
B	M6	M5	20	8	12	-	10	Stainless steel, NBR	134-000-717
B	G1/4	M16x1,5	41	8	13	20	17	stainless steel	134-000-716
C	G1/4	M10x1	74,5	11	16	-	17	stainless steel	134-000-714
D	M6x0,75	M6x0,75	26	15	8	-	8	Steel, burnished	134-000-718
D	M6x0,75	M6x0,75	21	10	8	-	8	Steel, burnished	134-000-719
D	R1/8	Rp1/8	28	13	9	-	13	Steel, burnished	134-000-720
D	R1/8	Rp1/8	35	20	9	-	13	Steel, burnished	134-000-721

# Tube connectors stainless Steel

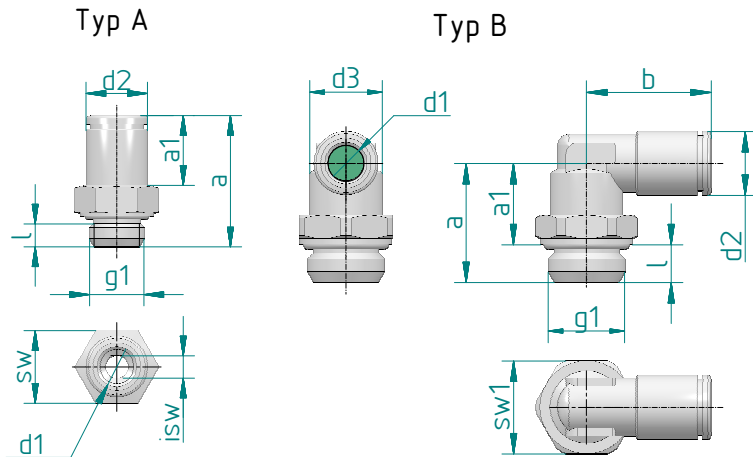

**Description type A:**  
 Tube connector straight  
 FDA-compliant

**Description type B:**  
 Tube connector right-angled;  
 360° rotatable; cylindrical thread  
 FDA-compliant

**Material:**  
 1.4401; Seal: FKM

type	d1	d2	a	a1	b	g1	l	sw	isw	part-no.
A	4	9	20,5	7	-	M5	4	9	-	134-000-901
A	4	9	19	9	-	G1/8	5,5	13	3	134-000-902
A	6	11	22,5	17,5	-	M5	4	-	2,5	134-000-904
A	6	11	23,5	12,5	-	G1/8	5,5	13	4	134-000-905
A	6	11	20	6	-	G1/4	6,5	16	4	134-000-906
A	8	13	26	14,5	-	G1/8	5,5	13	5	134-000-907
A	8	13	26	12	-	G1/4	6,5	16	6	134-000-908
B	4	9	14,8	10,8	18,2	M5	4	9	-	134-001-901
B	4	9	19,3	13,8	20	G1/8	5,5	13	-	134-001-902
B	4	9	20,5	14	20	G1/4	6,5	16	-	134-001-903
B	6	11	14,5	10,5	20,5	M5	4	9	-	134-001-904
B	6	11	19,3	13,8	21,5	G1/8	5,5	13	-	134-001-905
B	6	11	20,5	14	21,5	G1/4	6,5	16	-	134-001-906
B	8	13	19,3	13,8	23,5	G1/8	5,5	13	-	134-001-907
B	8	13	20,5	14	23,5	G1/4	6,5	16	-	134-001-908

# QuickGuide

## PU-Lubrication-roller with spring sheet

### Step 1:

Upon delivery the lubrication roller are pre-assembled

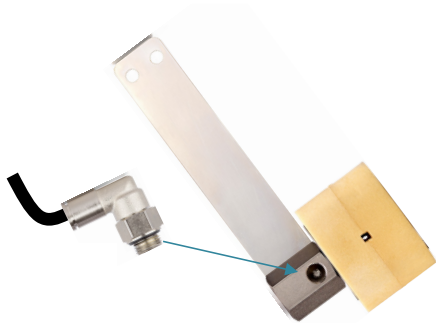

Please screw the fitting into the axis. The fitting has to be ordered separately!

Install the tubing

#### **Attention:**

Cut the tube only with tube cutter. Push the tube deep (approx. 18 mm) into the fitting. Remove the tube not more than two time, otherwise you have to shorten the tube about 5mm.

If you don't cut the end, leaks are possible!

### Step 2:

pre-fill the lubrication roller



Upon delivery, the lubrication roller are not pre-filled

Recommendation: 2 min in mineral oil. Put the lubrication roller around. Let the excess oil drain off

**ATTENTION:** never use the rollers in dry conditions!

### Step 3:

Assembly of lubrication roller

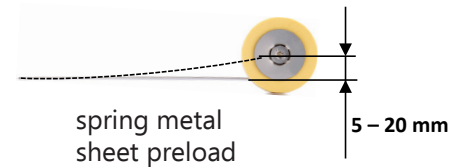

#### Installation details:

Make sure the roller is running parallel to the chain.

Starting with a width of around 60mm, please use double spring metal sheet!

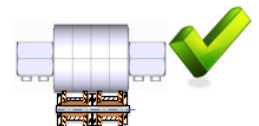

# QuickGuide

## PU-Lubrication-pinion

### Step 1:

Assembly  
lubrication-pinion on axis

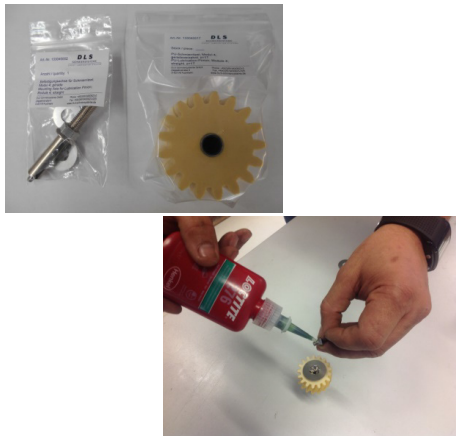

The lubrication-pinion will be delivered separately from the axis.

The lubrication-pinion and the axis are not mounted!

**The screw has to be glued into the axis!**

Take care, there is no glue between sleeve bearing of the pinion and the axis.

**The glue has to be dry out min. 7h**

### Step 2:

Connection with prefilled tubes

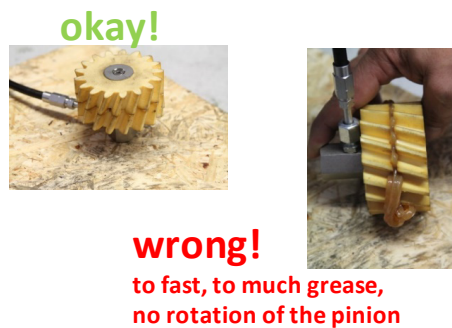

PU-lubrication pinions must be pre-oiled or pre-greased after assembly.

To do this, place the pinion in a mineral oil bath for approx. 10 minutes.

Then SLOWLY fill the lubricating gear with grease.

**ATTENTION: Never use the pinion in dry conditions!**

### Step 3:

Assembly of lubrication-pinions

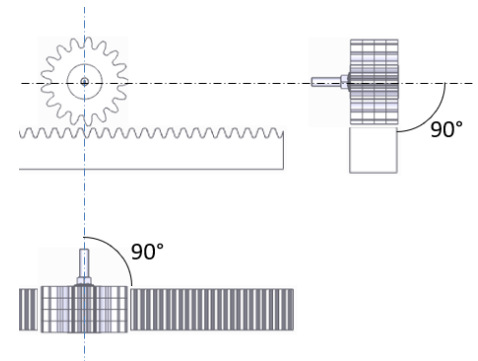

Installation details:

The lubrication-pinion has to be mounted very accurate, right angled into the moving direction.

Do not mount to tight!

**The pinion need clearance from 0,5 to 0,7mm!**



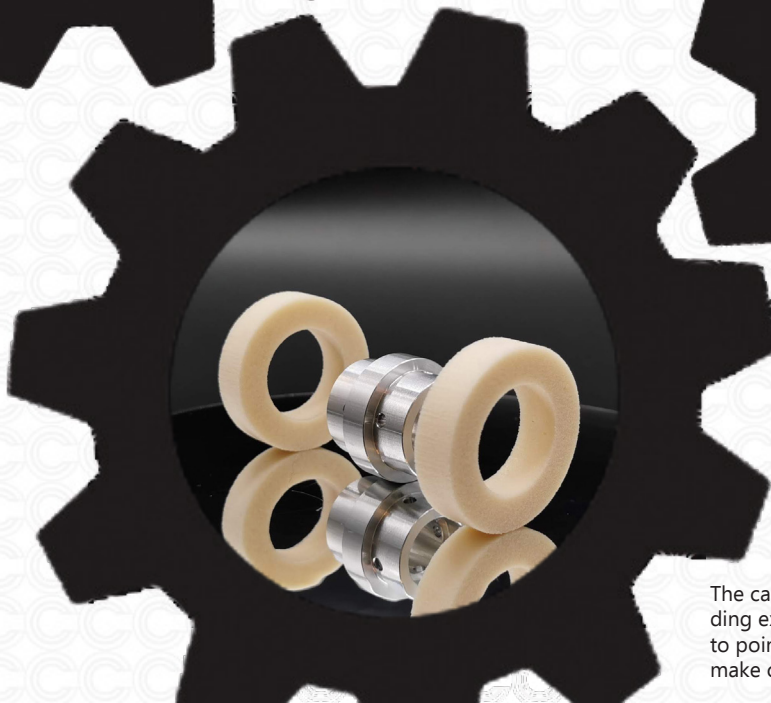

The catalog is protected by copyright. Reprinting, duplication and copies, including extracts, are only permitted with our express written consent. We would like to point out that all catalog data are only indicative and we reserve the right to make changes.



Triebstockzahnrad Modul 30

$Z=8$

$b=570$