

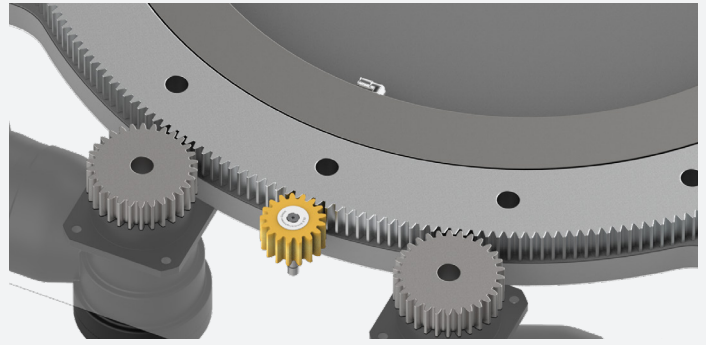

PU-Lubrication Pinion with axis

For relubrication of open gears

- + Operating temperature 0 °C to +120 °C
- + Light weight
- + Plain bearings
- + Geometry freely selectable
- + Special fastenings possible
- + Grease up to NLGI Class 2
- + Available with axle as a set (pre-oiled)
- + Stainless steel mounting axles



**- Designed by DLS -
Made in Germany!**

**PU-Lubrication pinions in all
sizes for all applications!**

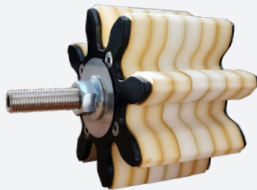

special PU-shapes for your lubrication



PU-brush for chain lubrication

PU-Applicator for ball screws or spindles:

The applicator ensures that maintenance intervals are extended and offers flexible mounting options on the ball screw drive.

Easy integration into our well-known lubrication system for the best and easiest supply.

Our polyurethane foam ensures long durability and even distribution of the lubricant.

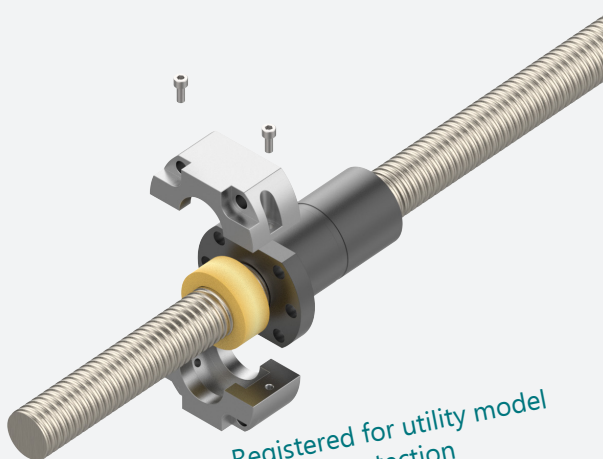

**Registered for utility model
protection**

Pumps for grease lubrication

- + Automatic relubricator
- + For grease and lubricants
- + Impulse or time controlled
- + up to 35 outlets; expandable through distribution system
- + different amounts of lubrication possible
- + For grease lubricants up to NLGI class 2
- + Delivery pressure up to 250 bar
- + Can be integrated into PLC with feedback
- + Installation position vertical (other installation positions on request)
- + different protection classes
- + large temperature range

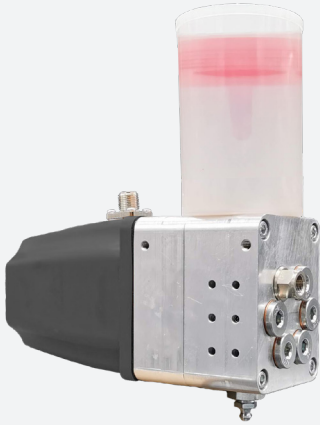

Pumps for oil lubrication

- + Automatic relubricator
- + For oil lubricants
- + Battery, time or pulse controlled
- + Oil with an operating viscosity of $150 \text{ mm}^2 / \text{s}$
- + Delivery pressure up to 70 bar
- + Installation position vertical (other installation positions on request)
- + different protection classes
- + large temperature range

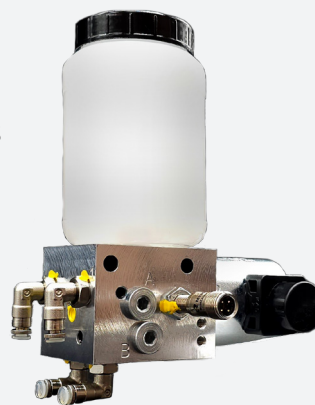

Distributors

For needs-based lubricant distribution

Solenoid valve strip 2-6 outlets

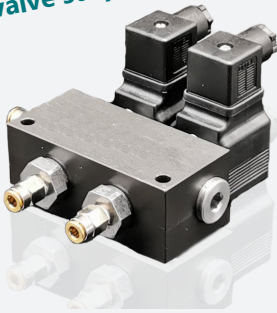

Different dosing volumes possible
High dosing accuracy of all distributors
For grease and oil lubricants



Flow distributor 2 or 4 outlets



Progressive distributor 2 - 14 outlets



2-way valve for direct mounting on the progressive distributor

Accessories

Selected accessories for your applications.



Cartridges

The right lubricant for every application!
Available from stock in many different container sizes



Tube connectors

For connecting the lubrication system to your lubrication point.

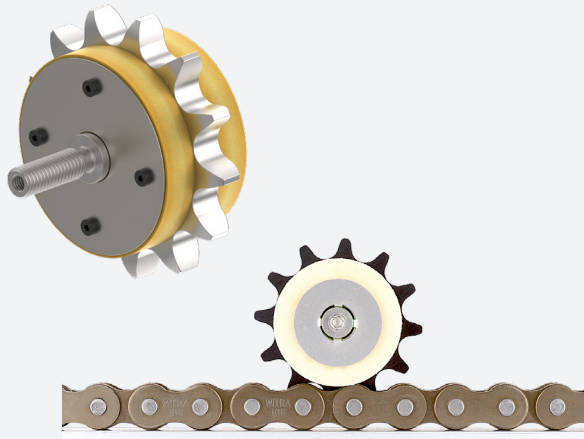

PU-Lubrication Sprockets

For relubricating chains

- Speeds also > 2 m/s
- Different fastenings
- Plain bearings
(Rolling bearings on request)
- For chain lubricating oils < 30,000 cSt
- Very good emergency running properties
- Up to size 32B

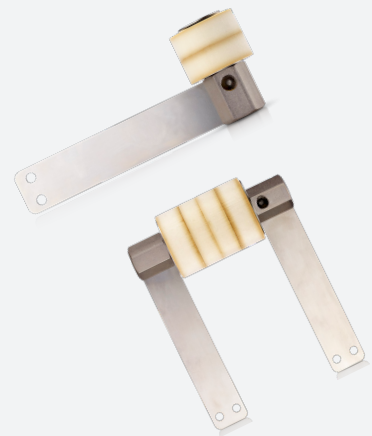

PU-Lubrication Rolls

For relubricating chains or rails for guides

- For grease or oil lubrication
- Grease up to NLGI Class 2 / Oil up to < 30,000 cSt
- Diameter up to 600 mm
- Contours freely selectable
- Very good emergency running properties
- Covers and enclosures on request
- Accumulation conveyor chains also possible

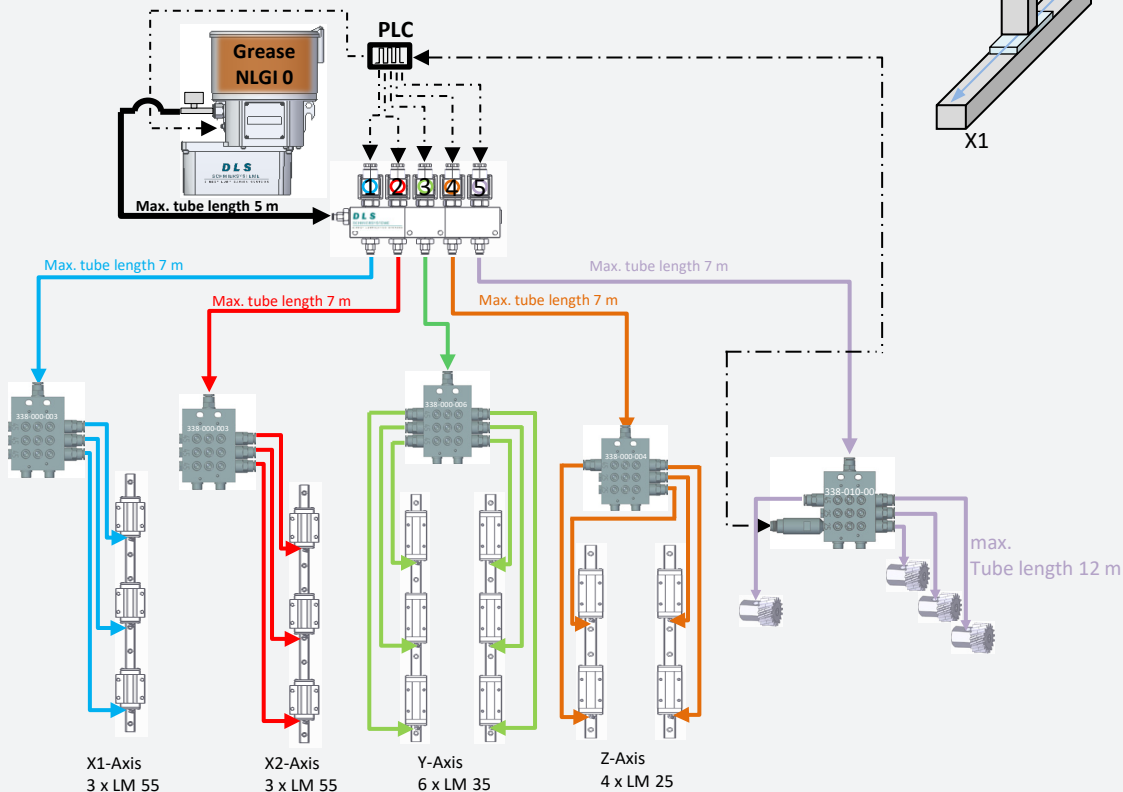
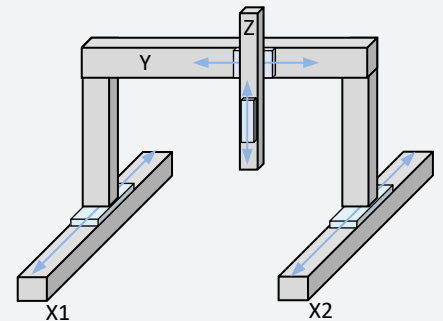

Address:

DLS Schmiersysteme GmbH
Gewerbering 5
82140 Olching
Deutschland



DLS Schmiersysteme GmbH is certified according to ISO 9001:2015.

Contact:

Phone +49 (0) 8142 650690
Mail mail@DLS-Schmiersysteme.com
order@DLS-Schmiersysteme.com
Internet www.DLS-Schmiersysteme.de



We are a successful training company.

From conception to on-time individual or series delivery:
All from a single source!

We advise you competently and solution-oriented directly on site!
Our team of experienced engineers and technicians looks forward to your challenges.

